

THE DIAPASON

JULY, 1993



Southminster Presbyterian Church, Arlington Heights, IL
Specification on page 14

Noehren: Modern Organ Design

Cheers to Robert Noehren for his article challenging what he terms current 'fashion' in organ building today. The inclusion of varying opinions and new ideas should always be encouraged, with the hope that they will result in further discussion and a higher level of the art form. In that vein I would like to offer some of my own observations on Mr. Noehren's ideas, and hope that we can 'agree to disagree.'

Can one infer from Mr. Noehren's article that he feels all organists should be able to play all repertoire well on all instruments? How would that compare to any other discipline? Do we not have doctors who specialize in prenatal care or in heart problems or car manufacturers who build sports cars or family cars, etc.? Don't we have a parallel with organists who specialize in North German, French Romantic, transcriptions and French Classic? Certainly these musicians have a diverse background, just as the doctors have pre-med school, but they have chosen to study, perform, teach and record a specific style of organ music.

Why should the study, construction and voicing of organs be different? Why should we ignore the talents of the craftsmen, the consultants, the voicers, not to mention the performers and the composers who have chosen to fine tune their skills in a particular style or tradition. Would it not be impractical to presume that we could bring all of these individual talents together to design one particular instrument with the purpose of serving all needs. Just as no automobile is both the ideal sports car and the ideal family car, there are different goals and different needs. Instead of serving all needs, would it not only serve to water down the traditions and styles which each of the artists had been striving to perfect, or would it run the chance of not serving any tradition or style sufficiently well?

One vivid experience was my first summer organ 'conference', at the House of Hope in St. Paul. We were able to experience a number of different styles of organ building in one location. I will never forget how I felt when I heard a Bach trio chorale on appropriate stops by an artist who had extensively studied this music, or a Widor movement on a French instrument by another artist who was equally well studied in this music. This combination of an instrument of a specific style, music chosen with regard to the instrument and style, and a performer well schooled in this style is not something we should forsake, but we should continue to strive towards this ideal.

Is not the diversity, the specialization and the variety what makes the organ so interesting and exciting? While I disagree with a few of Mr. Noehren's points in this article, I feel the need to rally against his fundamental proposition of a standard "... organ for our age." However, we should hope that this article will lead to further discussion as well as lead to a furthering of the art of organ building.

David Erickson
Chambersburg, PA

The author replies:

What do medicine and motor cars have to do with musical art? Not much, except to keep us healthy and perhaps transport us to an organ recital. But medicine today would never do without specialists. If I must have surgery, I look for the best specialist I can find, but in the greater world of music, the most eminent soloists and conductors would not like to be called specialists, even if, on occasion, they specialize in the music of one or another composer, for they all play and perform a large and representative repertoire written for their instruments.

As for motor cars, I don't know anyone

who now prefers a clumsy mechanical steering system to the sensitive and precise control of power steering. In fact, doctors and motor cars represent the most modern technology to be found in our complicated civilization, while organists and organ builders still insist on using a clumsy and antiquated action for control of the key-boards of their organs instead of developing a sensitive and flexible means to provide a far more subtle control of rhythm and expression in the art of making music.

But let's concentrate on music. Mr. Erickson is convincingly persuading us to maintain the best of the status quo of our little (comparatively speaking) organ world, and he seems quite content, like so many other organists, with the rather limited joys of its musical fare. I wonder if he would be so easily satisfied if he were to hear music from the larger world of music every day, as I do. It is not so easy then to go back and listen to the stiff playing of the great G-minor Fantasia of Bach by an organist on a stereotypical tracker organ after one has heard a Brahms or a Bruckner symphony played by one of the great orchestras of Chicago, Cleveland or New York, the vital performance of a Beethoven sonata by Stephen Bishop, the Etudes of Debussy so wonderfully played by Anthony di Bonaventura, a Chopin Mazurka by the pianist Moravec, the Korngold sonata for violin performed by Andre Granat, or the Hindemith violin concerto played by Joseph Fuchs.

Mr. Erickson seems to be "caught up" with the organs and its players of our time. Although I am an organist who has spent a lifetime trying to play and build organs, I am still "caught up" with music and the desire to hear it at the highest artistic level. Life is short and listening to music is one of my great passions.

Music, organists and organs are all indispensable in the performance of organ music. Music is the most important of the three, and the organist is more important than the organ, for it is he who must bring music to life.

Robert Noehren

Information requested

Over the last few years I have been able to locate quite a few organ scores by Latin American composers. I am trying to make as complete a list of compositions by Latin American composers as possible, and welcome information from anyone who would care to share names of composers or titles of compositions they may have in their possession or know of. I am also happy to share the results of my research with others who may be interested in the same subject. Please feel free to contact me:

James Welch
Music Dept., UCSB
Santa Barbara, CA 93106

**Box Phil-Rev
THE DIAPASON**

I am most pleased to testify to the effectiveness of your Philomela Revoicing Kit [THE DIAPASON, May 1993, p. 21], which has changed our rank of "burping Bourdons" into the sweetest, most luscious Philomela imaginable—a truly contemporary expression of the Greek myth of the daughter of a king of Athens who was transformed into a nightingale (ornithological name, *Daulias philomela*).

There have been some unanticipated consequences, however. The realistic avian-like warblings emanating from the revoiced ranks attracted a flock of the aforementioned species to take up residence in the organ chamber! While these cheerful chirpers already have provided authentic support for a recent performance of Handel's Organ Con-

THE DIAPASON

A Scranton Gillette Publication

Eighty-fourth Year, No. 7, Whole No. 1004
Established in 1909

JULY, 1993
ISSN 0012-2378

An International Monthly Devoted to the Organ, the Harpsichord and Church Music
Official Journal of the International Society for Organ History and Preservation

CONTENTS

FEATURES

Scaling Organ Pipes with a Computer
by Herbert L. Huestis & Warren P. Huestis 11

LETTERS TO THE EDITOR

Editor JEROME BUTERA

Associate Editor WESLEY VOS

Contributing Editors LARRY PALMER
Harpsichord

NEWS

Here & There 2, 3, 4, 5, 6
Appointments 3
Nunc Dimittis 4
Carillon News 6
Carillon Concert Calendar 6

JAMES McCRAY
Choral Music

HERBERT L. HUESTIS

IN-Group Forum
CompuServe ID #70771,1047
Internet: 70771.1047@compuserve.com

REVIEWS

Music for Voices and Organ 7
Book Reviews 8
New Recordings 9

BRIAN SWAGER
Carillon

NEW ORGANS

CALENDAR

ORGAN RECITALS

CLASSIFIED ADVERTISING

THE DIAPASON (ISSN 0012-2378) is published monthly by Scranton Gillette Communications, Inc., 380 E. Northwest Highway, Des Plaines, IL 60016-2282. Phone (708) 298-6622. Fax (708) 390-0408. Telex: 206041 MSG RLY.

Subscriptions: 1 yr. \$18; 2 yr. \$27; 3 yr. \$36 (United States and U.S. possessions). Foreign subscriptions: 1 yr. \$28; 2 yr. \$43; 3 yr. \$60. Single copies; \$3 (U.S.A.); \$5 (foreign).

Back issues over one year old are available only from The Organ Historical Society, Inc., P.O. Box 26811, Richmond, VA 23261, which can supply information on availabilities and prices.

Second-class postage paid at Des Plaines, IL, and additional mailing offices. POSTMASTER: Send address changes to THE DIAPASON, 380 Northwest Highway, Des Plaines, IL 60016.

Routine items for publication must be received six weeks in advance of the month of issue. For advertising copy, the closing date is the 1st. Prospective contributors of articles should request a style sheet. Unsolicited reviews cannot be accepted.

This journal is indexed in *The Music Index*, annotated in *Music Article Guide*, and abstracted in *RILM Abstracts*.

Copyright © 1993. PRINTED IN U.S.A.

Subscribers: Send subscriptions, inquiries and address changes to THE DIAPASON, 380 E. Northwest Highway, Des Plaines, IL 60016-2282. Give old and new addresses, including zip codes. Enclose address label from last issue and allow four weeks for change to become effective.

No portion of the contents of this issue may be reproduced in any form without the specific written permission of the Editor, except that libraries are authorized to make photocopies of the material contained herein for the purpose of course reserve reading at the rate of one copy for every fifteen students. Such copies may be reused for other courses or for the same course offered subsequently.

certo No. 13 ("Cuckoo and Nightingale"), their often tedious trilling at other times has become hard to bear. Also, they have developed the unwelcome habit of nesting in the columns of adjacent open pipes, thus lowering their pitch and raising clean-up and maintenance costs.

In more ways than one, then, the Philomela Revoicing Kit is "for the birds."

Jacobus Herzmann, Organist
St. Hylo's-in-the-Woods

Gertrud Mueller Nelson, R. William Franklin, Paul Manz, Gracia Grindal, John Bell, Philip Brunelle, and Trudy Faber in 30 workshops, worship in both traditional and innovative forms, and an orchestra and chorus of over 200 students from Lutheran Summer Music. A post-conference continuing education event, "Children in Worship," will feature David Holeton, Gerhard Cartford, and nine workshops. For information: ALCM, St. Luke ELCA, 9100 Colesville Rd., Silver Spring, MD 20910; 301/588-4363.

The Indiana Choral Directors Association presents its 1993 Summer Conference July 11-13 at Butler University, Indianapolis. Guests include Douglas McEwen, Axel Theimer, Denes Szabo, Henry Leck, and Vincent Lawrence, with performances by the Indianapolis Children's Choir, Kantemus-Hungarian Children's Choir, the South Bend Chamber Singers, and Swan Song. For information: ICDA Summer Conference, c/o Pat Wiehe, 2435 Glenhill, Indianapolis, IN 46240.

Master Schola '93 takes place August 10-16 at the Community of Jesus in Orleans, Massachusetts. Faculty includes Margaret Hillis, David Craighead, Mary Berry, and Craig Timberlake in lectures, masterclasses and seminars. Margaret Hillis will conduct the Fauré *Requiem* on August 15, and David Craighead will perform a recital August 10. For information: The Community of Jesus Master Schola, 5 Bay-

Here & There

The 19th Festival d'Orgue at Chartres Cathedral takes place July 4-September 5, and consists of weekly recitals by an international roster of performers: 7/4 Vincent Warnier, 7/11 George Baker, 7/18 Peter Bannister, 7/25 Thierry Escaich, 8/1 Iain Simcock, 8/8 François Clement, 8/15 Patrick Delabre, 8/22 Joseph Adam, 8/29 Bernhard Marx, and 9/5 Aude Heurtematte. For information: Administration Générale, 75 rue de Grenelle, 75007 Paris, France; tel: (1) 45.48.31.74.

The national conference of the Association of Lutheran Church Musicians takes place July 11-15 at Augsburg College, Minneapolis. Entitled "Sanctify Us While We Sing," the conference will feature presenters Diane Jacobson,

view Dr., P.O. Box 1094, Orleans, MA 02653; 1-800/252-7729.

The University of Minnesota will sponsor a Sacred Choral Repertoire Workshop August 9-14. Presenters include Philip Brunelle, Paul Salamunovich, Lorna Cooke deVaron, Stephen Paulus, Carolyn Jennings, and Sigrid Johnson. The workshop will include sacred choral literature from all periods of music, covering the church year from August to Pentecost, as well as festive occasions. For information: 612/624-6053.

On Sunday, August 15, Grace Cathedral and the San Francisco AGO Chapter will honor Richard Purvis on the occasion of his 80th birthday. There will be sung Evensong at 3:30 pm followed by a recital of his works played on the Cathedral's 5-manual Aeolian-Skinner organ, after which a reception will be held in Gresham Hall.

Mr. Purvis made his debut at the age of 10 at San Francisco's Civic Auditorium while a student of Wallace Sabin. He won a scholarship to the Curtis Institute of Music, studying with Alexander McCurdy and Joseph Levinne. As a recipient of a Curtis European travel fellowship, he studied with Sir Edward Bairstow at York Minster. Following World War II, he returned to San Francisco, where he was appointed Organist and Master of the Choristers at Grace Cathedral, a post he held for 25 years. During this time he also served as organist of the Palace of the Legion of Honor (IV/50 Skinner). His more than 200 published compositions encompass every medium available for church performance, from solo organ to complete liturgy.

Members of the AGO and friends of Mr. Purvis are encouraged to attend this event. To share information in the Remembrance Book, contact Paul Alan Rosendall, 319 Avalon Ave., San Francisco, CA 94112-2001.

The First International Marcel Dupré Academy takes place August 30-September 3 in Douai under the direction of Rolande Falcinelli. Assisting in the academy will be Françoise Levechin and Jean-Philippe Mesnier. Featured instruments include the Muhleisen organs at the Conservatoire and Eglise Notre-Dame, the Schyven at Eglise Saint-Jacques, and the Mutin-Cavaillé-Coll at Collégiale Saint-Pierre. For information: Secrétariat de l'A.D.A.O., 97 Square Bréguet, 59500 Douai, France.

The Seventh Académie Internationale d'Orgue des Andelys takes place September 6-14 in Les Andelys, France. The academy will focus on the organ, harpsichord and clavichord in France, England and Flanders from 1580 to 1660. Faculty includes Bob van Asperen, Bernard Winsemius, François Lengelle, Norbert Petri, and Etienne Baillot. For information: Académie Internationale d'Orgue des Andelys, B.P. 228, 27702 Les Andelys, France.

The Organ Historical Society is making available grant support to underwrite use of the American Organ Archives, housed at Talbot Library of Westminster Choir College, Princeton, New Jersey. Funding, to a maximum of \$1,000, will be made to offset a portion of the cost of travel to and from the collection and maintenance during the grantee's stay. Grantees must agree in writing to give the Society's journal and monograph series first refusal on any publishable research funded by the Society under this program. The Archives is the largest collection of its type and contains literature and primary material on American organ history, including complete runs of most 19th-century American music periodicals, foreign journals, the business records of numerous organ builders, drawings, photographs, etc.

The grants committee, consisting of William Paul Hays, Stephen L. Pinel, and John Ogasapian, will receive appli-

cations by December 1, 1993. Awards will be announced by January 30, 1994. For information: John Ogasapian, 217 Durgin Hall, University of Massachusetts, Lowell, MA 01854.

Appointments

Larry Tremsky has been appointed director of music at Grace Episcopal Church, Utica, New York, where he will direct the music program for the historic downtown parish, which includes an adult choir of volunteers and professional singers, as well as a boy choir, girl choir and handbell choir. He is responsible for playing the church's 1983 Holtkamp organ (III/67) and coordinating occasional concerts and organ recitals.

Tremsky comes to Grace Church from Holy Name Cathedral in Chicago, where he was associate organist-choirmaster for nine years and acting director of music during the 1991-92 sabbatical leave of the Cathedral's director of music, Richard Proulx. While at Holy Name, he was the organist for several recordings with the Cathedral choirs and served as accompanist for several choir tours, including one in Europe. He holds the BMus, magna cum laude, from the University of Cincinnati College-Conservatory of Music and the MMus from Northwestern University, Evanston. His organ teachers have included Wayne Fischer, David Mulbury, and Grigg Fountain.

Here & There

Gerald Bales' *Te Deum Laudamus* was included in two concerts (May 1 and 2) by the Thunder Bay Symphony Orchestra and Chorus. Conductor was Glenn Mossop, and Allan Bevin took part as organ soloist in Haydn's *Concerto in C* and as harpsichordist in Handel's *Zadok the Priest*. The concerts took place in St. Andrew's Presbyterian and St. Paul's United churches in Thunder Bay, Ontario.

Charles Callahan's *Meditation on a Medieval Tune* (Divinum Mysterium), has recently been issued in the Marilyn Mason Organ Series. The piece is available from the publisher, Randall M. Egan, Publisher of Music Ltd., Kenwood Abbey, 2024 Kenwood Pkwy., Minneapolis, MN 55405-2303.



Robert Cavarra

Robert Cavarra, Professor of Organ at Colorado State University, played for the 27th International Festival of Organists at the Cathedral of Morelia, Michoacan, Mexico, on May 24. This was Cavarra's second appearance, having played for the 14th Festival in 1974, when he also was a guest lecturer at the 1st International Congress of Latin American Organists, speaking on "Contemporary American Organ Building," featuring slides and tape recordings of the CSU Casavant organ. The Festival coincided with the anniversary of the founding of the city of Morelia.

Cavarra, partially sponsored by the Cultural Affairs Office of the U.S. Embassy, played a recital on the two newly rebuilt 17th-century organs in the Cathedral of Mexico City (May 31). Other

appearances in Mexico included the Cathedrals in Chihuahua (May 19), Guadalajara (May 21), Morelia (May 24), and at churches in Talpujahuá (May 25), Tacamero (May 27), and Patzcuaro (May 28). The tour ended with a series of harpsichord concerts, entitled "Bach sobre El Nido," for the Puerto Vallarta Music Club, on the roof-top gardens at the Cuatro Vientos Hotel.



Elizabeth & Raymond Chenault

Elizabeth & Raymond Chenault gave the world premiere of *Allegro for Organ Duet* by Philip Moore at Trinity College Chapel in Hartford on February 7. The Chenaults commissioned this work from the English composer who completed it in the summer of 1992. Philip Moore has been Organist and Master of the Music at England's York Minster since 1983. Many of the duo's organ duet commissions, now numbering more than 15, have been published by Belwin Mills in a collection entitled *The Chenault Organ Duet Library*. Gothic Records has recorded a number of these duets on their premiere recording *Twentieth Century Organ Music for Two*. The Chenaults concertize under the management of Phillip Truckenbrod Concert Artists, Hartford, Connecticut.

Douglas Cleveland, a graduate student at the Indiana University School of Music in Bloomington, was named winner of the 31st annual National Organ Playing Competition in the finals held April 24 at the First Presbyterian Church, Fort Wayne, Indiana. The six contest finalists were chosen from 33 preliminary tape-recorded entries. Cleveland was awarded a cash prize of \$1,000.00, and was presented in recital at First Presbyterian Church on May 25. He is currently studying organ with Larry Smith and is serving as assistant organist and choirmaster at Christ Church Episcopal Cathedral in Indianapolis.

A native of Washington State, he began his music training on the piano at age 5 and on the organ at age 13 with AGO past president Edward Hansen. While a high school student, he studied with Daniel Roth and Martin Haselböck at the Academy of Organists in Haarlem, The Netherlands. Later he played recitals in Austria, Germany, and Holland. In 1986 he began undergraduate organ studies at the Eastman School of Music, where he was a scholarship student of Russell Saunders. While at Eastman he won first prize in several national competitions including the 1990 Westminster Choir College Graduate Competition, the 1989 Organ Competition sponsored by the Luther Place Memorial Church in Washington, D.C., the 1988 Scarritt Competition, and the 1987 AGO Region VIII Young Artists Competition. He was also a finalist in the 1990 Calgary International Competition as well as the 1990 Grand Prix de Chartres. He has also been heard on National Public Radio's broadcast, *Pipedreams*. Prior to his current position, he served as assistant university organist at Washington University in St. Louis, and as assistant organist and choirmaster at the St. Louis Episcopal Church of St. Michael and St. George.

Second-place winner, Stephen Krahn, received a cash prize of \$500.00. A native of San Antonio, Texas, Krahn

is currently working on a DMA at the University of Nebraska, serving as staff accompanist at the University, and is organist at First-Plymouth Congregational Church in Lincoln. Krahn holds degrees in piano, organ, and church music from the Eastman School of Music and from Southern Methodist University. In 1990 he was a semi-finalist in the AGO National Organ-Playing Competition.

Other finalists included Esther Chang, who received her MMus at the Eastman School of Music where she studied organ with Russell Saunders, and who has more recently pursued the DMA as an organ student of Larry Smith at Indiana University; Kimberly Ann Hess, a DMA candidate in organ performance at the University of Illinois, where she studies with Michael Farris; Eric Riley, music director/organist at Calvary Presbyterian Church in Canton, Ohio, having received the BMus from Syracuse University and MCM degree from Scarritt Graduate School in Nashville, Tennessee, and currently coaching with Karel Paukert at the Cleveland Museum of Art; and Erik Suter, an undergraduate student of Haskell Thomson at the Oberlin Conservatory of Music.

Judging the contest finals were Roberta Gary, Robert Glasgow, and Todd Wilson. The competition is sponsored by the First Presbyterian Church Music Series, with additional support provided by a corporate grant from the Quimby Pipe Organ Company. Information regarding the 1994 competition may be received by writing to National Organ Playing Competition, First Presbyterian Church, 300 West Wayne at Webster, Ft. Wayne, IN 46802.

Catharine Crozier was in residence at the Wichita State University where she played four weekly Organ Vespers recitals on February 24, March 3, 10, and 17 on the 1986 (IV/85) Marcussen and Son organ in Wiedemann Recital Hall on the university campus. The series was reminiscent of the organ vespers recitals she played annually in the spring when she was the organist of Knowles Memorial Chapel and on the faculty of Rollins College, Winter Park, Florida. That model was the inspiration for Robert Town, Professor of Organ at Wichita State University, to begin a similar series there which he performed in 1991 and 1992.

Miss Crozier also gave a class on March 13 in Wiedemann Hall sponsored by the Wichita AGO Chapter. The topic was "A Retrospective of the Gleason Method of Organ Playing—Its Roots, Influences, Development and Application." Miss Crozier's vespers recitals were a part of the school's University Organ Series, 1992-1993 season. Other recitals in this season included Matthias Janz, Flensburg, on October 8, and Olivier Latry, Paris, on April 27.



Matthew Dirst

Matthew Dirst won second prize in April of this year at the inaugural Warsaw International Harpsichord Competition. He received 35,000,000 zł. in prize money and will return to Poland for a series of recitals next year. There

were 40 competitors from more than a dozen countries in the Warsaw finals. The jury for the event included Kenneth Gilbert (Canada and France), Huguette Dreyfus (France), Ketil Haug-sand (Norway), Christiane Jaccottet (Switzerland), Leszek Kedracki (Poland), Wladyslaw Klosiewicz (Poland and Austria), and Elzbieta Stefanska (Poland).

In 1990 Dirst won the AGO National Young Artists Competition, and since that time has played dozens of concerts across North America. He is a PhD candidate in musicology at Stanford University, where he is working with Bach scholar Laurence Dreyfus on a dissertation entitled *The Well-Tempered Clavier and Bach's Aesthetic Legacy*.

Works of Daniel Gawthrop received premiere performances in April. *A Washington Suite*, written for the Fairfax Symphony Orchestra as the ensemble's Composer-in-Residence, was premiered April 24. The humorous piece has five short movements: "Federal Fanfare," "March of the Bureaucrats," "Pork Barrel Polka," "Bipartisan Waltz" (in two keys), and "Procession of the Lobbyists." The composer is considering an organ transcription of the piece.

On April 25, Gawthrop was in Fresno, California, for the premiere of an a cappella choral work, *Bright Journeys: Songs of Love and Light*, commissioned by CSU Fresno for the dedication of their new music building. CSU's Concert Choir was joined by a community chorus under the direction of Gary Unruh.

Gawthrop is a member of the Washington, DC AGO Chapter, and past dean of the Salt Lake City Chapter. Both of the new works will be published by Dunstan House, P.O. Box 1355, Stafford, VA 22555; 703/659-8411.

Adrian Gunning is featured on a new CD recording, *L'Orgue Mystique, Charles Tournemire*, on the Libra Real-sound label (LRCD155). Performed on

the Harrison & Harrison organ at Coventry Cathedral, the recording includes movements from ten of the suites of *L'Orgue Mystique*. Available from The Organ Literature Foundation; 617/848-1388.



Hans Uwe Hielscher

Hans Uwe Hielscher was on a United States concert tour during January/February, 1993. In California, he played a carillon recital at the University of Riverside, an organ recital and lecture for the Seventh Annual Redlands Organ Festival as well as a recital at Pasadena Presbyterian Church. Other performance venues included The Nassau Cathedral, Bahamas; National City Christian Church, Washington, DC; First United Methodist, Little Rock, Arkansas; and Calvary Presbyterian Church, Memphis, Tennessee.

Hans Hielscher is organist and carillonneur at the Marktkirche in Wiesbaden, Germany, and is Municipal Organist for the concert hall in Wiesbaden. He has performed more than two thousand recitals throughout Europe and

the United States, and the French government has honored him with the "Chevalier of the Arts." His recordings for Motette-Ursina and his many programs for German Television feature music of the romantic era. His book on the life and times of Alexandre Guilmant is in its second printing. Plans are under way for a United States concert tour in January/February, 1994. Mr. Hielscher concertizes under the management of Artist Recitals Concert Promotional Service, Ruth Plummer, Representative.



Daniel Pinkham

Daniel Pinkham celebrated his 70th birthday on June 5. In honor of the occasion, the New England Composers Recording Project held a gala concert on June 4 in Faneuil Hall. Richard Dyer, music critic for the *Boston Globe*, presided over the festivities. The Lydian String Quartet performed Pinkham's *String Quartet*. The Boston Cecilia, under the direction of Donald Teeters, performed the *Christmas Cantata*. Also on the program was the comic opera, *Garden Party*.

To mark the birthday, the newly-formed Thorpe Music Publishing Company released two new works: *Wondrous Love*, a set of five easy variations for organ; and *Three Introits for Christmas-tide*, a set of short pieces for two-part chorus, recently premiered by the Women's Glee Club of the California Institute of Technology.

The New England Conservatory of Music presented Pinkham with his fourth honorary doctorate at commencement exercises on May 23.

James Welch performed a Christmas recital on December 5 at St. Mary's Cathedral, San Francisco. Joining him on the program were the Valparaiso Singers of Menlo Park, California, who sang the premiere of a new work, *The Three Women of Christmas*, by Mary Finlayson of Woodside, California. The work is scored for three women, tenor evangelist, and keyboard. For information about the work, contact James Welch, Music Dept., UCSB, Santa Barbara, CA 93106.

On April 29, Welch played his 10th annual recital for the students at Cate School, a private high school in Carpinteria, California. The school chapel has a Casavant organ, which was restored

in 1983 through a gift from Jacques Littlefield, class of '67 and currently a trustee of the school.



John Weaver

John Weaver is featured on a new CD recording, *John Weaver Performs*, on the Gothic label (G 49060). Performed on the 102-rank Schantz organ at East 91st St. Christian Church, Indianapolis, Indiana, the recording includes the *Cortège et Litanie* of Dupré; Six *Schübler Chorales*, Bach; *Roulade*, Bingham; *Ave Maria*, Schubert; *Fantasia for Organ*, Weaver; and the first recording of *Prelude, Scherzo and Pussacaglia* of Kenneth Leighton. (CD \$16.98 plus postage; cassette \$8.98 plus postage.) For information: Gothic Records, P.O. Box 1576, Tustin, CA 92681; 800/735-4720.

Here & There ►

Nunc Dimittis

Lady Susi Jeans died on January 7 at the age of 81. The Austrian-born organist and musicologist had pioneered the baroque revival in Britain and trained generations of musicians through the Box Hill Festival, which she ran at her home, Cleveland Lodge, near Dorking.

Born January 25, 1911 in Vienna, she studied piano and organ at the Vienna Conservatory. She made a career playing organ and clavichord recitals, doing research, writing and teaching. She collected musical instruments, including a three-manual organ, two water-organs, a double-manual harpsichord, and numerous spinets. Lady Jeans was much in demand as an adjudicator and taught at universities in American and Australia. In accordance with her wish, Cleveland Lodge is to be handed over to the Royal School of Church Music to continue as a center of teaching.

A festschrift, *Aspects of Keyboard Music: Essays in Honour of Susi Jeans*, edited by Robert Judd, was published shortly before her death. The festschrift was first presented to Lady Jeans on January 25, 1986, in honor of her 75th birthday, and is published by Positif Press.

The Young Organists Cooperative Ltd.

A non-profit management agency representing America's finest young artists

ROSTER

Brian Aranowski	Susan Klotzbach
Jonathan Biggers	Mark Laubach
John Bodinger	Susan Matteson
Jeffrey Brillhart	Katharine Pardee
Frank Corbin	Robert Poovey
Carla Edwards	Michael Velting
David Heller	Laura van der Windt
Michael Kaminski	Brett Wolgast

For information contact

Frank Corbin
 Founder and Managing Director
 26 Old English Road
 Worcester, Massachusetts 01609
 508/754-1168

SUSAN · CAROL · WOODSON

INTERNATIONAL · RECITALIST

ORGANIST-TITULARIS

Church of St. Michael & Peter · Antwerp, Belgium

--Susan Woodson's recording is distinguished by excellent playing and thoughtful interpretations. One hopes that it will be the first of many by a player who has much to say, and does so in an uncommonly articulate manner.

--The Diapason

Music für Orgel · REGER · LISZT

Compact Disc available through: The Organ Literature Foundation
 45 Norfolk Road · Braintree, Massachusetts · 02184-5915

RECITAL INQUIRIES: BP 14 · 1000 Brussels 22 · Belgium





First Presbyterian Church, Deerfield contestants (l to r) standing: Ian Woods, Edward Moore; seated: Erik Suter, Kimberly Hess, Stephen Tharp



First Presbyterian Church, Deerfield judges: Margaret Kemper, Merlin Lehman, Jerome Butera

Stephen Tharp from Arlington Heights, Illinois, is the first place winner in the **Fourth Annual Organ Competition** of the First Presbyterian Church, Deerfield, IL. The final round was held March 6, when five finalists performed. Second Place (\$400) was awarded to Kimberly Hess, a doctoral student at the University of Illinois, Urbana, and a student of Michael Farris. Other finalists included Edward Moore, a master's student at the University of Illinois, Urbana; Erik Suter, an undergraduate student at Oberlin Conservatory, Ohio; and Ian Woods, an undergraduate student at Stanford University, California.

Mr. Tharp was presented first prize money of \$750 at the winner's recital on March 21. He completed a BA degree in music, magna cum laude, at Illinois College in Jacksonville in 1992 studying organ with Rudolf Zuiderveld and piano with Garrett Allman. Further organ study included work with Jean Guillou, Wolfgang Rübsam, Harald Vogel and Gillian Weir, and in 1990 he attended the International Academy for Organists, Haarlem, The Netherlands. He is currently the Associate Director of Music at the First United Methodist Church of Springfield, Illinois, and is Sub-dean for the Springfield AGO Chapter. He was named second place winner in the 1992 Undergraduate Organ Competition of First Presbyterian Church, Ottumwa, Iowa, as well as National Winner in Organ at the Music Teacher's National Association's Collegiate Artists' Competition held in March, 1992, in Milwaukee.

The competition, sponsored by the church's Concert Series, attracted 12 entries from 10 states for the taped preliminary round. Judges for that round included Sally Cherrington, Robert Finster and Paul Vander Weele. Judges for the final round included Jerome Butera, Margaret Kemper and Merlin Lehman. Lee Nelson, Director of Music at the church, served as proctor.

The choirs of **The United Parish of Natick**, an association of the parishes of Christ Lutheran Church, First Baptist Church, First Congregational Church, and St. Paul's Episcopal Church, premiered *The Seven Last Words of Jesus Christ on the Cross* by Rodney Lister on Good Friday, April 9, at Christ Lutheran Church, Natick, Massachusetts. **James Moore**, Christ Lutheran Church Music Director, commissioned and conducted the music. **Karin Gustafson** was organist. The work, for mixed chorus, soloists, and organ, opens

and closes with sections of 17th-century poet Richard Crashaw's *Office of the Holy Crosse*. Soprano, alto, tenor, and bass soloists sing the parts of the Evangelists and the choir sings the words of Jesus. For information: Rodney Lister, 97 Oxford St., Somerville, MA 02143.

A performance of Brahms' *A German Requiem* took place at **Covenant Presbyterian Church**, Charlotte, North Carolina on April 4 under the direction of **Richard Peek**. Organist was **André Lash**, who also played two Brahms chorale preludes.

Adoro Fancy, a new work for organ, flute, oboe, and trumpet by **Charles Hoag**, Professor of Theory at the University of Kansas, received its premiere on September 12, 1992 by the **Deknatel Consort** at Bethel College, North Newton, Kansas. The work, commissioned by the ensemble in residence at Bethel College, is based on the chant *Adoro te Devote*. Members of the consort are **Shirley Sprunger King**, organ; **Lorraine Miller**, flute; **Donald Kehrberg**, oboe; and **Dwight Beckman**, trumpet.

Gothic Records has announced the release of Volume 5 of *Organ & Choral Music of Larry King* in the series "Music from Trinity Church Wall Street" (G

49056). The recording features the late **Larry King**, music director and organist; **James A. Simms**, associate and principal conductor; **Timothy Smith**, organist; and the **Choir of Trinity Church**, in works of King. For information: Gothic Records, P.O. Box 1576, Tustin, CA 92681; 800/735-4720.

Electric Theatre has produced a software package called *Keys to Music*. Volume I: *Learn to Read Music* covers musical terms, accidentals, note values and names, and basic rhythms. Volume II: *Learn to Write Music* includes time and key signatures and scales. Retail price for each volume is \$59.95. For information: Electric Theatre, 111 Holme Ave., #2, Elkins, PA 19117; 215/379-4538.

Paraclete Press has announced two releases by **Gloriae Dei Cantores**. *American Organ Music II—The Boston Classicists* (GDC 011) documents the sounds heard in concert halls such as Worcester's Mechanics Hall and Boston's Faneuil Hall with the music of **Buck, Paine and Parker**. *In Celebration of Christmas* (GDC 012) includes English carols, early American carols, handbell music, and a new work by **Gerald Near** entitled *Cum Novo Cantico*. Both are available in cassette (\$9.98) and CD

(\$15.98) formats. For information: 1-800/451-5006 ext 332.

Oxford University Press has announced the publication of *Exiles from Eden: Religion and the Academic Vocation in America*, by **Mark R. Schwehn**. The author is Professor of Humanities and Dean of Christ College, the honors college of Valparaiso University. The book deals with the many problems facing higher education and offers a prescription for a classroom-oriented spiritual community of scholars. For information: Oxford University Press, 2001 Evans Rd., Cary, NC 27513; 1-800/451-7556.

ChoralView, a recently developed computer program for IBM and Macintosh computer formats, has announced the release of a free demo disk. The *ChoralView* program contains the review information of all choral reviews published by THE DIAPASON, ACDA, AGO, *Creator Magazine*, AGEHR, and Choristers Guild. The program enables users to locate music by title, composer, historical period, liturgical season, source of the text, voicing, age of choir and style, such as jazz, spirituals, carols, etc. Sample copies of octavos are also available to *ChoralView* subscribers at a nominal

Wicks

1100 5TH STREET HIGHLAND, IL 62249 TEL (618) 654-2191 FAX (618) 654-3770



RECENT RESTORATION AND ADDITIONS AT THE BASILICA OF ST. LOUIS KING OF FRANCE (OLD CATHEDRAL), ST. LOUIS, MO

BUILDING THE LEGACY OF MUSIC

Company portfolio available upon request.



New company video available to interested persons.

charge. The free demo disk is available by calling 1-800/736-0595, and leaving name, address, phone, type of computer and disk size.

Glory Sound, a division of Shawnee Press, has announced the release of a solo piano recording, *American Tapes*, by Joseph M. Martin. The recording features hymns and folk songs and is available on cassette (NC-5047, \$10.98) and CD (ND-5003, \$14.98). Glory Sound has also released a piano collection, *Medleys of Praise*, arranged by Don Wyrzten. The publication contains medleys of familiar hymns for many occasions and seasons during the church year. For information: Shawnee Press, 49 Waring Dr., Delaware Water Gap, PA 18327; 1-800/962-8584.

A comprehensive restoration plan to identify, prioritize and coordinate repairs to the organ and building at **Methuen Memorial Music Hall** has been developed. Built in 1863 by E.F. Walker for the old Boston Music Hall, the organ was purchased by Edward F. Searles of Methuen in 1897, rebuilt and installed in a specially-built concert hall. In 1947, G. Donald Harrison of the Aeolian-Skinner Company completed an extensive tonal reconstruction. The organ comprises five divisions, 84 stops, 115 ranks, and 6,027 pipes. To help fund the repairs, a series of seven cassette recordings has been released, each of which contains over 70 minutes of music and is a compilation of season highlights from the annual recital series. The 1992, 1991, 1990, 1989, 1988, 1987 and 1986 season cassettes are available for \$12.00 each; all seven \$70.00 postpaid: Restoration Fund Cassettes, Methuen Memorial Music Hall, 38 Chestnut Ct., North Andover, MA 01845-5320.

A **Rodgers Oxford 945** digital organ has been purchased and installed in Phoenix's new American West Arena by the Phoenix Suns NBA basketball team. The three-manual instrument includes a Rodgers PR-300 digital sequencer/sound module, giving it prerecord and playback capabilities. The new organ features a special "theatrical style" Flash EPROM. The sound module generated voices are used for contemporary music and the creation of sound effects.

Carillon News by Brian Swager

Johan Franco Composition Competition

The Guild of Carillonneurs in North America has announced a composition competition for new music for carillon. The piece must be written for an instrument of up to 48 bells with a compass of C,D,E, then chromatic through c². First and second prizes will be \$800 and \$400. The deadline for entries is January 15, 1994. A 90-minute videotape demonstrating aspects of playing and composing for the carillon, geared toward composers, is available for \$15 postpaid. For further details about the competition, and to obtain the videotape, contact John Gouwens, Attn. Composition Competition, CMA Box

133, Culver, Indiana 46511.

Two compositions sponsored by the Johan Franco Composition Fund were premiered at the 1992 Congress of the GCNA. *Easter Dawning*, by George Crumb, commissioned by the guild, was given its first performance by Don Cook, University Carillonneur of Brigham Young University, on June 13 in Dayton, Ohio. The dramatic new work, the first carillon composition by Crumb, melds elements of Russian bell music—as depicted in the music of Rachmaninov and Mussorgsky—with many traits of Crumb's own style. The piece is published by C.F. Peters Corporation. *Evocation*, by John Courter, won Second Prize in the 1992 Carillon Composition Competition sponsored by the GCNA. Mr. Courter is Professor of Music at Berea College, Berea, Kentucky, and is active in both the carillon and organ fields. *Evocation*, which is published by GCNA, was performed in recital at Mariemont, Ohio on June 15 by Brian Swager, University Carillonneur of Indiana University.

1993 Carillon Concert Calendar

1 JULY
Dionisio Lind; First Presbyterian, Stamford, CT 7 pm
George Matthew, Jr.; Trinity United Methodist, Springfield, MA 7 pm

2 JULY
George Matthew, Jr.; Yale University, New Haven, CT 7 pm

3 JULY
Brian Swager; Culver Academy, Culver, IN 4 pm
Richard Watson; First United Methodist of Germantown, Philadelphia, PA 7:30 pm

4 JULY
Mark Konewko; Rockefeller Memorial Chapel, Chicago, IL 6 pm
Terence McKinney; St. Stephen's, Cohasset, MA 6 pm
Phillip Burgess, with Detroit Symphony Brass; Christ Church Cranbrook, Bloomfield, Hills, MI 4 pm

5 JULY
Mark Konewko; Chicago Botanic Garden, Glencoe, IL 7 pm
Terence McKinney; Municipal Building, Norwood, MA 7 pm
George Matthew, Jr.; University of Michigan, Ann Arbor, MI 7 pm

6 JULY
Frank DellaPenna; Alfred University, Alfred, NY 7 pm

7 JULY
Frank DellaPenna; Calvary Episcopal, Williams-ville, NY 7 pm
Terence McKinney; Our Lady of Good Voyage, Gloucester, MA 7 pm
Robert Shelton Wright; Trinity College, Hartford, CT 7 pm

8 JULY
Brian Swager; Metz Memorial Carillon, Bloomington, IN 7:30 pm
David Hunsberger; Trinity United Methodist, Springfield, MA 7 pm
Daniel Kehoe; First Presbyterian, Stamford, CT 7 pm
George Matthew, Jr.; University of Wisconsin, Madison, WI

9 JULY
George Matthew, Jr.; University of Wisconsin, Madison, WI

10 JULY
Brian Swager; Culver Academy, Culver, IN 4 pm

11 JULY
David Hunsberger; St. Stephen's, Cohasset, MA 6 pm
Claude Aubin; First Presbyterian, Stamford, CT 11 am
Frank DellaPenna; Christ Church Cranbrook, Bloomfield Hills, MI 4 pm
George Matthew, Jr.; Rockefeller Chapel, Chicago, IL

12 JULY
David Hunsberger; Municipal Building, Norwood, MA 7 pm
Frank DellaPenna; University of Michigan, Ann Arbor, MI 7 pm
Todd Fair; First United Methodist of Germantown, Philadelphia, PA 7:30 pm
George Matthew, Jr.; Chicago Botanic Garden, Glencoe, IL

13 JULY
Joanne Droppers; Alfred University, Alfred, NY 7 pm

14 JULY
David Hunsberger; Our Lady of Good Voyage, Gloucester, MA 7 pm
Claude Aubin; Trinity College, Hartford, CT 7 pm
Gloria Werblow; Calvary Episcopal, Williams-ville, NY 7 pm

15 JULY
Claude Aubin; Trinity United Methodist, Springfield, MA 7 pm
George Matthew, Jr.; First Presbyterian, Stamford, CT 7 pm
Carol Jickling Lens; University of Wisconsin, Madison, WI

16 JULY
Claude Aubin; Yale University, New Haven, CT 7 pm

17 JULY
Brian Swager; Culver Academy, Culver, IN 4 pm

18 JULY
Thomas Reif; Rockefeller Chapel, Chicago, IL 6 pm
Todd Fair; Christ Church Cranbrook, Bloomfield Hills, MI 4 pm
Claude Aubin; St. Stephen's, Cohasset, MA 6 pm

19 JULY
Thomas Reif; Chicago Botanic Garden, Glencoe, IL 7 pm
Janet Tebbel; First United Methodist of Germantown, Philadelphia, PA 7:30 pm
Todd Fair; University of Michigan, Ann Arbor, MI 7 pm
Claude Aubin; Municipal Building, Norwood, MA 7 pm
Robin Austin; University of Rochester, Rochester, NY 7 pm

20 JULY
Robin Austin; Alfred University, Alfred, NY 7 pm

21 JULY
Robin Austin; Calvary Episcopal, Williams-ville, NY 7 pm
Lucy Dechène; Our Lady of Good Voyage, Gloucester, MA 7 pm
Peter Langberg; Trinity College, Hartford, CT 7 pm

22 JULY
Brian Swager; Metz Memorial Carillon, Bloomington, IN 7:30 pm
Peter Langberg; Singing Tower, Luray, VA 8 pm
Sally Slade Warner; Trinity United Methodist, Springfield, MA 7 pm
Marletta Storm Douglas; First Presbyterian, Stamford, CT 7 pm
Gert Oldenbeuving; University of Wisconsin, Madison, WI

23 JULY
Gert Oldenbeuving; Yale University, New Haven, CT 7 pm

25 JULY
Brian Swager; Christ Church Cranbrook, Bloomfield Hills, MI 4 pm
Peter Langberg; St. Stephen's, Cohasset, MA 6 pm
Gert Oldenbeuving; First Presbyterian, Stamford, CT 11 am
Todd Fair; Rockefeller Chapel, Chicago, IL

26 JULY
Brian Swager; University of Michigan, Ann Arbor, MI 7 pm
Peter Langberg; Municipal Building, Norwood, MA 7 pm
Beverly Buchanan; University of Rochester, Rochester, NY 7 pm

27 JULY
Beverly Buchanan; Alfred University, Alfred, NY 7 pm

28 JULY
Peter Langberg; Our Lady of Good Voyage, Gloucester, MA 7 pm
Gert Oldenbeuving; Trinity College, Hartford, CT 7 pm
Beverly Buchanan; Calvary Episcopal, Williams-ville, NY 7 pm

29 JULY
Gert Oldenbeuving; Singing Tower, Luray, VA 8 pm
Joseph Davis; First Presbyterian, Stamford, CT 7 pm
Brian Swager; University of Wisconsin, Madison, WI

30 JULY
Peter Langberg; Yale University, New Haven, CT 7 pm

1 AUGUST
Bill DeTurk & Beverly Buchanan, duets; Christ Church Cranbrook, Bloomfield Hills, MI 4 pm
Raymond Jay Fry; Rockefeller Memorial Chapel, Chicago, IL 6 pm

2 AUGUST
Janet Tebbel; University of Michigan, Ann Arbor, MI 7 pm
Edward Nassor; University of Rochester, Rochester, NY 7 pm
Karel Keldermans; First United Methodist of Germantown, Philadelphia, PA 7:30 pm
Raymond Jay Fry; Chicago Botanic Garden, Glencoe, IL 7 pm

3 AUGUST
Brian Swager; The Rochester Carillon, Rochester, MN 8 pm
Edward Nassor; Alfred University, Alfred, NY 7 pm

4 AUGUST
Marilyn Clark; Our Lady of Good Voyage, Gloucester, MA 7 pm
Suzanne Gates; Trinity College, Hartford, CT 7 pm
Edward Nassor; Calvary Episcopal, Williams-ville, NY 7 pm

5 AUGUST
Brian Swager; Metz Memorial Carillon, Bloomington, IN 7:30 pm

6 AUGUST
Karel Keldermans; Yale University, New Haven, CT 7 pm

7 AUGUST
David Breneman; Netherlands Carillon, Arlington, VA
Edward Nassor; Singing Tower, Luray, VA 8 pm

8 AUGUST
Janet Tebbel; Christ Church Cranbrook, Bloomfield Hills, MI 4 pm
Karel Keldermans; First Presbyterian, Stamford, CT 11 am
Karel Keldermans; St. Stephen's, Cohasset, MA 6 pm
Bill DeTurk; Rockefeller Chapel, Chicago, IL

9 AUGUST
Karel Keldermans; Municipal Building, Norwood, MA 7 pm
Bill DeTurk; Chicago Botanic Garden, Glencoe, IL

11 AUGUST
Karel Keldermans; Trinity College, Hartford, CT 7 pm

15 AUGUST
Carol Jickling Lens; Christ Church Cranbrook, Bloomfield Hills, MI 4 pm
Lucy Dechène; St. Stephen's, Cohasset, MA 6 pm
Susan Gentry; Rockefeller Memorial Chapel, Chicago, IL 6 pm

16 AUGUST
Lucy Dechène; Municipal Building, Norwood, MA 7 pm
Susan Gentry; Chicago Botanic Garden, Glencoe, IL 7 pm

19 AUGUST
Jim Fackenthal; Metz Memorial Carillon, Bloomington, IN 7:30 pm

20-23 AUGUST
Berkeley Carillon Festival; University of California, Berkeley, CA

10 JULY
Brian Swager; Culver Academy, Culver, IN 4 pm

11 JULY
David Hunsberger; St. Stephen's, Cohasset, MA 6 pm
Claude Aubin; First Presbyterian, Stamford, CT 11 am
Frank DellaPenna; Christ Church Cranbrook, Bloomfield Hills, MI 4 pm
George Matthew, Jr.; Rockefeller Chapel, Chicago, IL

12 JULY
David Hunsberger; Municipal Building, Norwood, MA 7 pm
Frank DellaPenna; University of Michigan, Ann Arbor, MI 7 pm
Todd Fair; First United Methodist of Germantown, Philadelphia, PA 7:30 pm
George Matthew, Jr.; Chicago Botanic Garden, Glencoe, IL

13 JULY
Joanne Droppers; Alfred University, Alfred, NY 7 pm

14 JULY
David Hunsberger; Our Lady of Good Voyage, Gloucester, MA 7 pm
Claude Aubin; Trinity College, Hartford, CT 7 pm
Gloria Werblow; Calvary Episcopal, Williams-ville, NY 7 pm

15 JULY
Claude Aubin; Trinity United Methodist, Springfield, MA 7 pm
George Matthew, Jr.; First Presbyterian, Stamford, CT 7 pm
Carol Jickling Lens; University of Wisconsin, Madison, WI

16 JULY
Claude Aubin; Yale University, New Haven, CT 7 pm

17 JULY
Brian Swager; Culver Academy, Culver, IN 4 pm

18 JULY
Thomas Reif; Rockefeller Chapel, Chicago, IL 6 pm
Todd Fair; Christ Church Cranbrook, Bloomfield Hills, MI 4 pm
Claude Aubin; St. Stephen's, Cohasset, MA 6 pm

19 JULY
Thomas Reif; Chicago Botanic Garden, Glencoe, IL 7 pm
Janet Tebbel; First United Methodist of Germantown, Philadelphia, PA 7:30 pm
Todd Fair; University of Michigan, Ann Arbor, MI 7 pm
Claude Aubin; Municipal Building, Norwood, MA 7 pm
Robin Austin; University of Rochester, Rochester, NY 7 pm

20 JULY
Robin Austin; Alfred University, Alfred, NY 7 pm

21 JULY
Robin Austin; Calvary Episcopal, Williams-ville, NY 7 pm
Lucy Dechène; Our Lady of Good Voyage, Gloucester, MA 7 pm
Peter Langberg; Trinity College, Hartford, CT 7 pm

22 JULY
Brian Swager; Metz Memorial Carillon, Bloomington, IN 7:30 pm
Peter Langberg; Singing Tower, Luray, VA 8 pm
Sally Slade Warner; Trinity United Methodist, Springfield, MA 7 pm
Marletta Storm Douglas; First Presbyterian, Stamford, CT 7 pm
Gert Oldenbeuving; University of Wisconsin, Madison, WI

23 JULY
Gert Oldenbeuving; Yale University, New Haven, CT 7 pm

25 JULY
Brian Swager; Christ Church Cranbrook, Bloomfield Hills, MI 4 pm
Peter Langberg; St. Stephen's, Cohasset, MA 6 pm
Gert Oldenbeuving; First Presbyterian, Stamford, CT 11 am
Todd Fair; Rockefeller Chapel, Chicago, IL

26 JULY
Brian Swager; University of Michigan, Ann Arbor, MI 7 pm
Peter Langberg; Municipal Building, Norwood, MA 7 pm
Beverly Buchanan; University of Rochester, Rochester, NY 7 pm

27 JULY
Beverly Buchanan; Alfred University, Alfred, NY 7 pm

28 JULY
Peter Langberg; Our Lady of Good Voyage, Gloucester, MA 7 pm
Gert Oldenbeuving; Trinity College, Hartford, CT 7 pm
Beverly Buchanan; Calvary Episcopal, Williams-ville, NY 7 pm

29 JULY
Gert Oldenbeuving; Singing Tower, Luray, VA 8 pm
Joseph Davis; First Presbyterian, Stamford, CT 7 pm
Brian Swager; University of Wisconsin, Madison, WI

30 JULY
Peter Langberg; Yale University, New Haven, CT 7 pm

1 AUGUST
Bill DeTurk & Beverly Buchanan, duets; Christ Church Cranbrook, Bloomfield Hills, MI 4 pm
Raymond Jay Fry; Rockefeller Memorial Chapel, Chicago, IL 6 pm

2 AUGUST
Janet Tebbel; University of Michigan, Ann Arbor, MI 7 pm
Edward Nassor; University of Rochester, Rochester, NY 7 pm
Karel Keldermans; First United Methodist of Germantown, Philadelphia, PA 7:30 pm
Raymond Jay Fry; Chicago Botanic Garden, Glencoe, IL 7 pm

3 AUGUST
Brian Swager; The Rochester Carillon, Rochester, MN 8 pm
Edward Nassor; Alfred University, Alfred, NY 7 pm

4 AUGUST
Marilyn Clark; Our Lady of Good Voyage, Gloucester, MA 7 pm
Suzanne Gates; Trinity College, Hartford, CT 7 pm
Edward Nassor; Calvary Episcopal, Williams-ville, NY 7 pm

5 AUGUST
Brian Swager; Metz Memorial Carillon, Bloomington, IN 7:30 pm

6 AUGUST
Karel Keldermans; Yale University, New Haven, CT 7 pm

7 AUGUST
David Breneman; Netherlands Carillon, Arlington, VA
Edward Nassor; Singing Tower, Luray, VA 8 pm

8 AUGUST
Janet Tebbel; Christ Church Cranbrook, Bloomfield Hills, MI 4 pm
Karel Keldermans; First Presbyterian, Stamford, CT 11 am
Karel Keldermans; St. Stephen's, Cohasset, MA 6 pm
Bill DeTurk; Rockefeller Chapel, Chicago, IL

9 AUGUST
Karel Keldermans; Municipal Building, Norwood, MA 7 pm
Bill DeTurk; Chicago Botanic Garden, Glencoe, IL

11 AUGUST
Karel Keldermans; Trinity College, Hartford, CT 7 pm

15 AUGUST
Carol Jickling Lens; Christ Church Cranbrook, Bloomfield Hills, MI 4 pm
Lucy Dechène; St. Stephen's, Cohasset, MA 6 pm
Susan Gentry; Rockefeller Memorial Chapel, Chicago, IL 6 pm

16 AUGUST
Lucy Dechène; Municipal Building, Norwood, MA 7 pm
Susan Gentry; Chicago Botanic Garden, Glencoe, IL 7 pm

19 AUGUST
Jim Fackenthal; Metz Memorial Carillon, Bloomington, IN 7:30 pm

20-23 AUGUST
Berkeley Carillon Festival; University of California, Berkeley, CA

Carol Jickling Lens; First United Methodist of Germantown, Philadelphia, PA 7:30 pm
Todd Fair; Chicago Botanic Garden, Glencoe, IL

27 JULY
Beverly Buchanan; Alfred University, Alfred, NY 7 pm

28 JULY
Peter Langberg; Our Lady of Good Voyage, Gloucester, MA 7 pm
Gert Oldenbeuving; Trinity College, Hartford, CT 7 pm
Beverly Buchanan; Calvary Episcopal, Williams-ville, NY 7 pm

29 JULY
Gert Oldenbeuving; Singing Tower, Luray, VA 8 pm
Joseph Davis; First Presbyterian, Stamford, CT 7 pm
Brian Swager; University of Wisconsin, Madison, WI

30 JULY
Peter Langberg; Yale University, New Haven, CT 7 pm

1 AUGUST
Bill DeTurk & Beverly Buchanan, duets; Christ Church Cranbrook, Bloomfield Hills, MI 4 pm
Raymond Jay Fry; Rockefeller Memorial Chapel, Chicago, IL 6 pm

2 AUGUST
Janet Tebbel; University of Michigan, Ann Arbor, MI 7 pm
Edward Nassor; University of Rochester, Rochester, NY 7 pm
Karel Keldermans; First United Methodist of Germantown, Philadelphia, PA 7:30 pm
Raymond Jay Fry; Chicago Botanic Garden, Glencoe, IL 7 pm

3 AUGUST
Brian Swager; The Rochester Carillon, Rochester, MN 8 pm
Edward Nassor; Alfred University, Alfred, NY 7 pm

4 AUGUST
Marilyn Clark; Our Lady of Good Voyage, Gloucester, MA 7 pm
Suzanne Gates; Trinity College, Hartford, CT 7 pm
Edward Nassor; Calvary Episcopal, Williams-ville, NY 7 pm

5 AUGUST
Brian Swager; Metz Memorial Carillon, Bloomington, IN 7:30 pm

6 AUGUST
Karel Keldermans; Yale University, New Haven, CT 7 pm

7 AUGUST
David Breneman; Netherlands Carillon, Arlington, VA
Edward Nassor; Singing Tower, Luray, VA 8 pm

8 AUGUST
Janet Tebbel; Christ Church Cranbrook, Bloomfield Hills, MI 4 pm
Karel Keldermans; First Presbyterian, Stamford, CT 11 am
Karel Keldermans; St. Stephen's, Cohasset, MA 6 pm
Bill DeTurk; Rockefeller Chapel, Chicago, IL

9 AUGUST
Karel Keldermans; Municipal Building, Norwood, MA 7 pm
Bill DeTurk; Chicago Botanic Garden, Glencoe, IL

11 AUGUST
Karel Keldermans; Trinity College, Hartford, CT 7 pm

15 AUGUST
Carol Jickling Lens; Christ Church Cranbrook, Bloomfield Hills, MI 4 pm
Lucy Dechène; St. Stephen's, Cohasset, MA 6 pm
Susan Gentry; Rockefeller Memorial Chapel, Chicago, IL 6 pm

16 AUGUST
Lucy Dechène; Municipal Building, Norwood, MA 7 pm
Susan Gentry; Chicago Botanic Garden, Glencoe, IL 7 pm

19 AUGUST
Jim Fackenthal; Metz Memorial Carillon, Bloomington, IN 7:30 pm

20-23 AUGUST
Berkeley Carillon Festival; University of California, Berkeley, CA

KEITH SCUDAMORE & Company

Pipe Organ Builders

We are traditional pipe organ builders based in Southern England, interested in high quality contracts to rebuild present instruments or build new organs, preferably mechanical action. Historical organs restored and shipped to U.S.A.

Unit 22, Liberty Close, Woolsbridge Ind. Park,
Three Legged Cross, Wimborne, Dorset BH21 6SY, U.K.
Telephone: (0202)827695 Fax: (0202)814065

20 AUGUST
Ronald Barnes, John Agraz, Jeff Davis, David Hunsberger; Sather Tower, University of California, Berkeley, CA 4 pm

21 AUGUST
Don Cook; Sather Tower, University of California, Berkeley, CA 11 am
John Courter; Sather Tower, University of California, Berkeley, CA 3:30 pm

22 AUGUST
Jenny King; Christ Church Cranbrook, Bloomfield Hills, MI 4 pm
Daniel Kehoe; Trinity College, Hartford, CT 7 pm
Luc Rombouts; Sather Tower, University of California, Berkeley, CA 2 pm
Gordon Slater; Sather Tower, University of California, Berkeley, CA 3:30 pm
Edward Nassor; Rockefeller Memorial Chapel, Chicago, IL 6 pm

23 AUGUST
Carlo van Uffit; Sather Tower, University of California, Berkeley, CA 1 pm
Bernard Winsemius; Sather Tower, University of California, Berkeley, CA 3 pm
Edward Nassor; Chicago Botanic Garden, Glencoe, IL 7 pm

25 AUGUST
Larry Weinstein; Trinity College, Hartford, CT 7 pm
Edward Nassor; The Rochester Carillon, Rochester, MN 8 pm

29 AUGUST
Dennis Curry; Christ Church Cranbrook, Bloomfield Hills, MI 4 pm
Sally Slade Warner; St. Stephens, Cohasset, MA 6 pm
Brian Swager; Rockefeller Memorial Chapel, Chicago, IL 6 pm

30 AUGUST
Sally Slade Warner; Municipal Building, Norwood, MA 7 pm
Brian Swager; Chicago Botanic Garden, Glencoe, IL 7 pm

5 SEPTEMBER
Philip Burgess, with the White Heather Highlanders (bagpipes & drums); Christ Church Cranbrook, Bloomfield Hills, MI 4 pm

Music for Voices and Organ

by James McCray

Old Testament Texts

It is a commonplace notion that there is in the great religions of the world a vast body of sacred literature—the Bible, the Vedas, the Qur'an, the Lotus Sutra and so on . . . The world's sacred texts are potent sources of inspiration and behaviour and, more importantly, they play a crucial part in the formation of peoples' perception of reality.

Ninian Smart and Richard Hecht

The above statement comes from the introduction of a fascinating book titled *Sacred Texts of the World, A Universal Anthology*. This collection addresses Christianity, Hinduism, Buddhism, Jainism, Taoism, Confucianism, and many other religions through their texts. Similarities abound and certain universal characteristics can be traced throughout the world and the centuries. This book is a delightful resource in comparing religions; one realizes how Christian faith stems from other previous faiths.

The Bible's two main divisions of Old and New Testaments have provided composers with inspirational words. Composers usually set Biblical or poetic texts. Sometimes they combine them and even shape the traditional texts by adding their own words to help highlight or emphasize ideas. Christian churches usually follow a common lectionary for public worship in which texts are identified for specific Sundays. For example, in the Methodist lectionary each Sunday is assigned a text for an Act of Praise (usually a Psalm), an Old Testament reading, an Epistle, and a Gospel. Some denominations follow

these lectionary lists with closely related music (Lutherans for example), while others choose more general music texts and make little attempt at unifying the service through lectionary texts. Psalms and the Gospel for example, may be read rather than sung.

Some music publishers have addressed this situation by identifying the exact Sunday appropriate for the music. They also publish lists of anthems and service music for each Sunday. Most choir directors have an abundance of Psalm texts. Other less popular texts may have only one or two settings. It is, certainly, a challenge to plan the music according to the lectionary.

Choir directors are urged to begin to compile their own useful list of texts based on the library of their individual church. With the computer it would be very simple to go through the library and create a listing of texts. They could be organized by books of the Bible and easily updated as new music is added to the library. Then it would be easy to compare the lectionary for the year with the texts available (most library collections are organized by composer and/or

title which may not be specific enough to mention text sources). While it may seem to be a mammoth project (and for huge churches it may be), it can be a lasting and highly useful contribution for the current choir as well as future groups. If you are computer friendly, it would probably take less than one day to organize it all by text, and think of all the time you would save in selecting literature in the future. The reviews below all are of Old Testament texts.

Text: Solomon 3:13. The Souls of the Righteous, Ronald Arnatt. SATB unaccompanied, E.C. Schirmer, No. 1.3234, no price given (E).

Here is a two-page setting with a short soprano or tenor solo. A slow, quiet setting with warm harmonies that could even serve as incidental music for funerals.

Text: Isaiah 61:1-3. Good Tidings to the Meek, Randall Thompson (1899-1984). SATB unaccompanied, Thorpe Music Publishing (Presser), 392-03012, \$1.20 (M).

The composer indicates that the

voices may be doubled by strings. This is from a new series of quality choral music by major composers which merits attention. This movement is from Thompson's *Requiem*, a double chorus work, but only the last three measures require divided choir (to a Habakkuk 1:5 text) and that could be sung by a solo quartet. Warm harmonies, voice crossings, and a simple, clear approach to the text are in evidence.

Text: Song of Solomon 2:10-14. Arise, My Love, Craig Carnahan. SATB, piano, and 3 octave handbells, Augsburg Fortress, 11-10298.

This common text has been paraphrased by the composer. The handbells are accompanimental and not difficult; their music is included separately at the back of the score. The tuneful music gently flows in 6/8 with the choir often independent from the piano. The ranges are comfortable with the choir sometimes in unison or two parts. Very attractive setting.

Text: Habakkuk I. For Lo, I Raise up, Charles Villiers Stanford (1852-1924).

Allen invites
 you to experience
 the MDS-93,
 one of several
 four-manual
 organs from the
 world's largest
 organ builder.

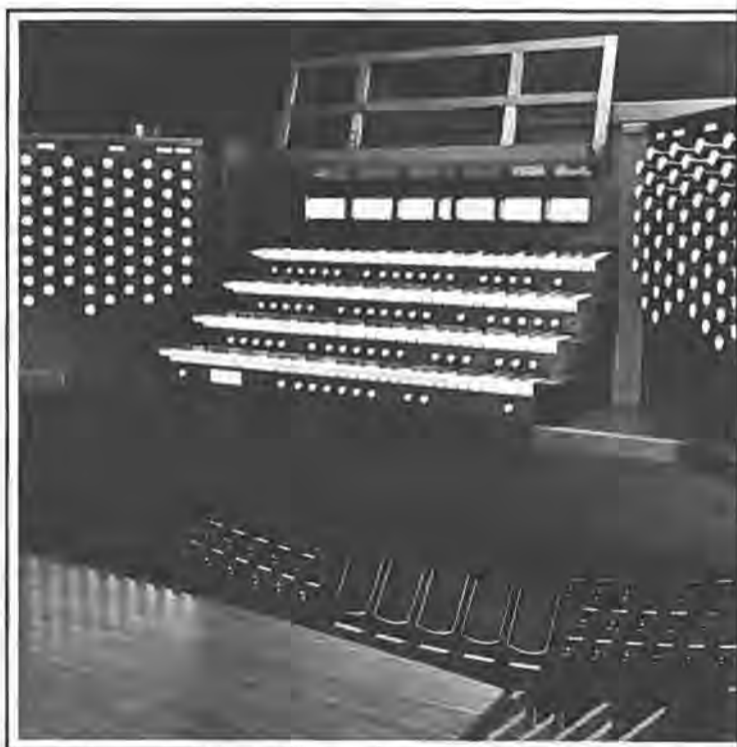

GREAT

- 16 Contra Gemshorn
- 8 Principal
- 8 Rohrflöte
- 8 Gemshorn
- 8 Flute Celeste II
- 4 Octave
- 4 Spitzflöte
- 4 Flute Celeste II
- 2 1/2 Quinte
- 2 Super Octave
- 2 Waldflöte
- Mixture IV
- Scharf III
- 16 Posaune
- 8 Trompette
- 8 Cromorne
- 4 Klarine
- Tremulant
- 8 Trompette en Chamade

SOLO

- 8 Diapason
- 8 Flauto Mirabilis
- 8 Viola Pomposa
- 8 Viola Celeste
- 4 Octave
- 4 Concert Flute
- Grand Jeu VI
- 16 Bombarde
- 8 Trompette Harmonique
- 8 Corno di Bassetto
- 8 French Horn
- 4 Clairon
- Tremulant

SWELL

- 16 Bourdon doux
- 16 Violone
- 16 Violone Celeste
- 8 Geigen Diapason
- 8 Flüte bouchée
- 8 Flüte Harmonique
- 8 Salicional
- 8 Voix Celeste
- 8 Voix Celeste (-)
- 4 Principal Conique
- 4 Flüte à fuseau
- 4 Salicet
- 4 Salicet Celeste
- 2 1/2 Nazard
- 2 Flüte à bec
- 1 1/2 Tierce
- 1 Sifflet
- Plein Jeu IV
- 16 Contre Trompette
- 16 Contre Basson
- 16 Vox Humana
- 8 Trompette
- 8 Hautbois
- 8 Vox Humana
- 4 Clairon
- Tremulant
- 4 Swell to Swell
- Unison Off
- 16 Swell to Swell
- 8 Trompette en Chamade

CHOIR

- 16 Quintaton
- 8 Holzgedackt
- 8 Erzähler
- 8 Erzähler Celeste
- 4 Spitzprincipal
- 4 Koppelflöte
- 4 Erzähler
- 4 Erzähler Celeste
- 2 1/2 Nasat
- 2 Oktav
- 2 Blockflöte
- 1 1/2 Terz
- 1 1/2 Quintflöte
- Cymbale III
- 16 Dulzian
- 8 Kleine Trompette
- 8 Cor Anglais
- 4 Rohr Schalmey
- Tremulant
- 8 Trompette en Chamade

SECOND VOICES (CHOIR)

- Orchestral Flute
- Clarinete
- Brass I
- Brass II
- Orchestral Oboe

PEDAL

- 32 Contre Basse
- 32 Contre Bourdon
- 32 Contre Violone
- 16 Diapason
- 16 Bourdon
- 16 Violone
- 16 Lieblichgedackt
- 8 Octave
- 8 Violoncello
- 8 Gedacktflöte
- 4 Choral Bass
- 4 Flüte ouverte
- 2 Zauberflöte
- Mixture IV
- Scharf III
- 32 Contre Bombarde
- 32 Kontra Fagott
- 16 Bombarde
- 16 Fagott
- 8 Trompette
- 4 Clairon
- 8 Trompette en Chamade

ANCILLARY

- Chrysoglott
- 8 Harpsichord
- 4 Harpsichord Handbells
- Celesta
- Harp
- Chimes

COUPLERS

- 8 Great to Pedal
- 8 Swell to Pedal
- 4 Swell to Pedal
- 8 Choir to Pedal
- 8 Solo to Pedal
- 16 Swell to Great
- 8 Swell to Great
- 4 Swell to Great
- 8 Choir to Great
- 8 Solo to Great
- 16 Swell to Choir
- 8 Swell to Choir
- 4 Swell to Choir
- 8 Solo to Choir
- 8 Solo to Swell
- 8 Ancillary to Pedal
- 8 Ancillary to Great
- 8 Ancillary to Swell
- 8 Ancillary to Choir
- MIDI to Solo
- MIDI to Swell
- MIDI to Great
- MIDI to Choir
- MIDI to Pedal

Call or write for free audio tape.



Copyright © 1993
 Macungie, PA 18062-0036
 215-966-2202

SATB and organ, Wayne Leupold Editions, WL 10-0001 (ECSchirmer), no price given (M+).

Stanford, the great British transitional composer into the 20th century, uses the organ as an equal partner to the choir. Its music is busy, on three staves, yet still accompanimental. There is a brief soprano recitative solo in the middle. The choir has some divisi areas which balance with the unison passages. Robust, romantic harmonies and chromaticism abound.

Text: Isaiah 61:1-3, 10. *The Spirit of the Lord*, Op. 53, Edwin H. Lemare (1865-1934). SATB, baritone solo, and organ, Leupold Editions (ECSchirmer, WL 10 0011), no price given (M+).

This extended Romantic period motet begins with a long organ solo that leads to the challenging baritone solo which dominates the first seven pages; the choir is in the last half. The organ is less busy with the choir, often playing their parts, which is in sharp contrast to the first half where it remained soloistic. Full, chromatic harmonies and dramatic gestures are used.

Text: Isaiah 60:1-2. *Arise, Shine, for Your Light has Come*, Hal Hopson. G.I.A. Publications, G-3428, \$.90 (E).

This Epiphany anthem opens with a unison choir above some rhythmic punctuating organ chords in a fanfare style. The SATB choir then moves to slower flowing lines for the main body of the setting. The last section is a two-part canon that builds to a bold, loud chordal ending. Very effective yet not difficult.

Text: Psalm 95:1-7. *Venite, Exultemus* (O Come Let Us Sing Unto The Lord), Halsey Stevens (1908-1989). SATB and keyboard or brass quintet, Mark Foster Music Co., MF 2096, \$1.40 (M+).

Stevens' style uses dancing rhythms of changing meters in which the accompaniment is sometimes quite incidental to the choir. Lean lines, mild disso-

nances, and facile technique bring a scholarly approach to the music—challenging, but well within the ability level of accomplished church choirs. The brass parts are available from the publisher.

Text: Psalm 129 (or commonly 130). *De Profundis* (A Song of Hope), Adrian Willaert (c. 1490-1562). SATB-SATB and organ, C.F. Peters, No. 67337, \$4.25 (M+).

This fine edition by Ralph Hunter includes an English version for performance. The two choirs are separate and rarely perform at the same time, with the organ used as a doubling support for the voices. A solo voice sings a plainsong line for the opening phrase. The music is not difficult (less than seven minutes), with comfortable ranges and limited contrapuntal writing. Highly recommended to good choirs.

Text: Psalm 98:4-6. *Make A Joyful Noise*, Don Whitman. SATB unaccompanied, Golden Music Publishers (National Music Pub.), H.12, no price given (M).

National (NMP) has acquired the Golden Music Publishers complete catalogue which contained many excellent choral settings that have been out-of-print/circulation for some time. (Write for catalogue.) This fine setting is rhythmic, well articulated, and most effective. The style is festive and will appeal to singers and audience. Excellent repertoire for church or school.

of Toronto Press, 1992. 1524 pages. \$95.00.

Encyclopedias, as attempts to present all the information their authors have collected about aspects of the world, have been around since the earliest days of Roman civilization. Unlike more specialized reference works, such as dictionaries, directories, who's whos, and the like, encyclopedias are self-contained works comprising comprehensive and cumulative summaries of what is known under each topic. All encyclopedias share a common theme: they are reflections of those developments of scholarship that contribute significantly to the improvement of human knowledge and understanding.

The first edition of the *Encyclopedia of Music in Canada* was initiated by a distinguished retired Toronto publisher, Floyd S. Chalmers, who had read a magazine article noting the lack of printed information about Canada's musical culture. [Reviewer's note: Mr. Chalmers died in Toronto, Canada, on April 26, 1993, at the age of 94.] He organized a group of musicians, scholars, and businessmen for the purpose and also led the drive for funding to complete the project. After nine years in preparation, the first edition was published in English in 1981, followed by an edition in French in 1983. From the outset, *EMC 1* was conceived neither as a seamless historical outline nor as a Canadian version of a general reference work on music. Rather, it was intended to describe Canada's musical culture in all its dimensions and diversity, both historically and in contemporary terms. Accordingly, its broad scope included references to music of all sorts: concert, folk, religious, popular, and other forms, and also dealt with these in their administrative, commercial, critical, and educational manifestations. While music encyclopedias in other countries had an established body of research upon which to draw, the scarcity of information in some Canadian categories required that the editors of *EMC* assign reliable writers to the task of discovering it. Thus the *EMC* venture has stimulated the acquisition of knowledge rather than just retrieving it.

Although the first edition was favorably received by scholars, people in the information trades, and the musical public generally, the following years were marked by considerable expansion and maturation of musical activity. In particular, the major developments relating to music in the 1980s included advances in electronic technologies, the rise of cultural industries, and demographic trends involving intercultural interaction. These were the major factors leading to the decision to prepare

this new edition, begun in 1988, completed in 1991, and published in the following year. Like its predecessor, this new edition is directed to both experts and laypersons, scholars as well as students, and adopts nontechnical language throughout.

While we often think of encyclopedias just as reference works to be taken down from library shelves on rare occasions, *EMC 2* can provide a relatively integrated educational experience, if approached in a systematic fashion. (The cover-to-cover approach is not recommended, for this would take about five days or 120 hours of non-stop reading.) A better method is to start with the entries on Canadian cities, where most of the musical activity takes place, beginning with Montréal (the second-largest French-speaking city in the world, where more streets, schools, and parks are named after musicians than in other cities), Toronto (the most populous city in English-speaking Canada), and Vancouver (the country's Pacific port and third-largest city). Each of these is distinguished, in its own way, by nationally and internationally recognized symphony orchestras, chamber ensembles, choirs, performing groups, musical festivals, clubs, organizations, and educational institutions. Similar types of activity, although on a smaller scale, are to be found in the smaller cities, which are also inventoried.

The system of cross-referencing employed throughout *EMC 2* allows the reader to proceed to the self-contained entries on performing musicians, teachers, composers, conductors, scholars, educators, critics, and administrators whose contributions to the local, regional, national, or international musical communities are presented in greater detail. These sections are mainly biographical, and those on composers and performers often include critical assessments excerpted from music magazines or other print media sources. Some entries include whole families of individuals whose musical achievements span several generations.

While much of the country's musical heritage has been passed from one generation to the next through private teaching, a greater part of practical and theoretical musical instruction in Canada has taken place within the more formal settings of established educational institutions. The extent of this activity can be grasped by consulting the entries on 41 Canadian universities which have music schools, as well as the account of the Royal Conservatory of Music in Toronto.

Information relating to specific instruments—their makers, players, teachers, composers, societies, etc.—is

Book Reviews

Encyclopedia of Music in Canada, 2nd edition, edited by Helmut Kallmann and Gilles Potvin, and associate editors Robin Elliott, Mark Miller. University

Organbuilders have been recycling for centuries.

WE RECYCLE TOO!



Altarpiece from 1891 in the new case
Pipework from the previous 1958 instrument

Christ Episcopal Church
La Crosse, Wisconsin

2 Manuals • Mechanical Action • 27 Stops • Electric Stop Action

ROBERT L. SIPE, INC.

ORGAN BUILDERS

Mechanical and Electric Action Slider Chest Organs

7307 Fenton Drive, Dallas, Texas 75231
(214) 341-0185 Fax (214) 341-4207

ORGAN AND CHORAL MUSIC
recorded in Britain's Historic Cathedrals, Churches, and Schools
by Abbey of Oxford. FREE Catalog
from: Bradford Consultants, P.O.
Box 4020, Alameda, CA 94501.

H.W. DEMARSE
TRACKER ORGANS

518-761-0239
2 Zenus Dr., Queensbury, NY 12804-1930

Schantz

Since 1873

Schantz Organ Company • Orrville, Ohio 44667 • 216/682-6065 • Member APOBA

concentrated in the relevant entries ranging through the alphabet from "Accordian" to "Violin." A general overview of the place of the organ in Canadian musical culture can be acquired through articles on organ history (beginning around 1660) and organ building (beginning in the early 19th century, including Casavant Frères and other leading artisans). On the practical side, there are sections on organ compositions and composers, organ playing, church music traditions, organ teaching in the Royal Conservatory of Music and at the universities, and the Calgary International Organ Festival. Professional interests are covered in an article on the Royal Canadian College of Organists (founded in 1909). There are also brief sections on the harpsichord (building, composition, playing) and on Canada's eleven carillons.

Information on more specific topics and their musical connections can be found in the dictionary-style entries on anthems, broadcasting, concerts, conductors, dance bands, emigration, folk music, gospel music, hymns, iconography, jazz, kilties, libraries, musical theatre, neoclassicism, opera, periodicals, rock music, serialism, transportation, unions, wars, and youth orchestras, among others. Musical activity in Canada's less visible cultures is covered in new material included in *EMC 2* on ethnomusicology, First Nations research, Inuit (Eskimo) music, Native North Americans in Canada, and other ethnic groups.

An understanding of the musical links between Canada and the rest of the world can be derived from the entries on specific countries on the alphabetical scale from Australia to the United States, both of which have striking parallels and differences with regard to the musical development of Canada. The country's debts to imported musical influences from Black Africa, Caribbean countries, England (always a dominant presence), Japan, and other nations, are also recorded. On the export side, many Canadians—pianists, instrumentalists, and singers—have furthered their careers through extensive tours or permanent relocation in other countries.

Finally, on this exploratory excursion through Canada's multi-faceted musical life, the attentive reader will have acquired some fascinating pieces of information, including some Canadian "firsts," that might be included in a future musical trivia quiz game: Canada's first music teacher¹, the youngest concertmaster of the Royal Philharmonic Orchestra under Sir Thomas Beecham², the internationally renowned singer who abandoned the opera stage and joined Mother Teresa in Calcutta to work with the terminally ill³, a former president of the Canadian College of Organists who thought the organ a dull instrument and organ recitals boring⁴, the youngest student in the history of Indiana University's music school in the United States⁵, the man who became known as Canada's musical elder statesman⁶, the internationally acclaimed jazz pianist who received ten honorary doctorates⁷, one of the first musicians of completely professional calibre born in Canada⁸, the first North American baroque orchestra to tour Europe⁹, Canada's world-class pianist who could read music at the age of three and made his debut as an organist¹⁰, and the only known descendant of J.S. Bach living in Canada¹¹.

A simple rehearsal of the basic statistics of *EMC 2* (over 3,100 entries, 540 contributors, extensive bibliographies, lists of compositions, discographies, indexes, etc.) is inadequate to convey the scope and depth of this superb volume. Moreover, its significance and usefulness will vary from one reader to another. Some Canadians will enrich their own personal histories through the discovery of information contained in the biographies of teachers, composers, or performers they know or have encountered, and in accounts of musical organizations or institutions that are part of their present or past experience. For

the majority of readers, however, *EMC 2* will serve as the standard reference work which chronicles the achievements of many hundreds of creative individuals whose contributions to Canada's musical culture deserve to be more widely appreciated both at home and abroad. Unlike other encyclopedias, *EMC 2* has an even greater goal envisaged by its editors:

Common to the diversified strands of Canada's cultural life during the 1980s, there has been one major concern, a concern for the survival and strengthening of an identity within the world community, establishing an independent Canadian voice in the concert of nations. Creating [this] tool for self-knowledge is an essential step in this process . . . (p. xvi).

—James B. Hartman
The University of Manitoba
Winnipeg, MB, Canada

Notes

1. Mother Marie de St-Joseph, who arrived in Canada in 1639 to instruct French and native girls in hymn singing, viol playing, and dancing.
2. Violinist Steven Stratyk, in the mid-1950s.
3. Soprano Teresa Stratas, in 1981.
4. Healy Willan (1880-1968), composer, church musician, organist, choir conductor, teacher; president of the CCO 1922-3, 1933-5; University of Toronto organist, 1932-64; honorary president and life member, Royal Canadian College of Organists. (However, he had a reputation for facetious wit.)

5. Violin prodigy Corey Cerovsek, at the age of 12, in 1984, when he also received a gold medal from the Royal Conservatory of Music for highest achievement in Canada. He received the D.Mus. from Indiana University in 1991, at the age of 19.
6. Sir Ernest Macmillan (1893-1973), organist, pianist, composer, educator, writer, administrator; knighted in 1935 for services to music in Canada.
7. Oscar Peterson, between 1973 and 1985.
8. Calixa Lavalée (1842-91), composer of the national anthem, "O Canada."
9. Tafelmusik chamber ensemble, founded in Toronto in 1978; first toured Europe in 1984, then annually beginning in 1987.
10. Glenn Gould, in a Casavant Society recital in Toronto in 1945.
11. John Sebastian Peter Bach, retired teacher, performer, conductor, former principal violist with the Calgary Philharmonic; claims descent through J.S. Bach's son, Johann Christoph Friedrich, and grandson, Wilhelm Friedrich Ernst.

New Recordings

Cook 'n Bacon. Marian Ruhl Metson, organ. Raven Recordings, 3217 Brook Rd., Richmond, VA 23227. OAR-210. Available in record stores or from The Organ Historical Society, P.O. Box 26811, Richmond, VA 23261. \$14.98 plus \$1.85 post. DDD 57'35".

Contents: Bacon, *Spirits and Places*; *Trumpet Tune*; *Cook, Fantasy on a Scottish Hymn Tune*, *Martyrs*; *Variations on*

Alles ist an Gottes Segen; *Improvisation on Veni Creator Spiritus*.

The title is witty, annoying, or both; nevertheless, it seems inevitable for this recording. Ernst Bacon's *Spirits and Places*, subtitled "Bicentennial cycle honoring American Personages and Geography of the native soil," is the most substantial work on this recording. A "kind of song cycle," according to Ms. Metson's notes, it suggests Rorem's *Quaker Reader* and *Views from the Oldest House*, albeit in a considerably more accessible style. Each movement bears the name of a place, a correlative quotation from an American writer, and a brief description of the compositional concept involved. (For instance: *Cabin in the Rain, Katahdin Cabin, Maine*. "In the night we were entertained by the sound of raindrops on the cedar shakes that covered the roof." Henry David Thoreau. Black against white keys.) These movements are fascinating in their geographic, literary, and musical variety, and Ms. Metson plays them with obvious relish and familiarity. The other Bacon work recorded here, a manuscript *Trumpet Tune*, is an attractive (if lightweight) essay. We can be sincerely grateful to Fred Tulan, who persuaded Bacon to write both these works, without condoning the sophistic humor in his published note

peterson
ELECTRO-MUSICAL PRODUCTS, INC.

Modern
Technology
Skillfully
Applied



To Enhance
the Art of
Pipe Organ
Performance

From the leading supplier of solid state equipment to the pipe organ industry comes the most advanced yet easy-to-use combination system ever developed...the MASTER STOP PROCESSOR MSP-1000™ by PETERSON.

To learn how the complete line of Peterson products can optimize the results of your pipe organ building or rebuilding project, contact your organ builder or PETERSON ELECTRO-MUSICAL PRODUCTS, INC.

11601 S. Mayfield Avenue\Worth, Illinois 60482\1-800-341-3311

regarding registrations, which Ms. Metson includes in the brochure at the expense of more enlightening information.

Look in vain here for the famous Cook *Fanfare*. Instead, Ms. Metson records three works in variation form. The *Fantasy on . . . Martyrs* (also in manuscript) alternates rhapsodic passages with contrapuntal episodes by turn austere and dramatic. The strong *Variations on Alles ist an Gottes Segen* in its ten partita-like verses provides a scenic tour through the colors of the organ. *Veni creator* examines various moods of the well-known plainsong. Early in *Martyrs* an almost brittle non-legato strikes me as curious. Still, Ms. Metson plays this music convincingly and with great authority.

Cook played the organ; I suspect Bacon did not, and I find it interesting to compare their approaches to the instrument. Cook's music is comfortably idiomatic. Bacon writes in a somewhat less obvious style. Would it occur to an organist to end a cycle with a movement based on "free use of guitaristic chords"? Nevertheless, in Ms. Metson's performance, *Spirits and Places* is undoubtedly successful organ music.

The recording features two Bozeman organs, both with gorgeous, contrasting cases: St. Paul's Episcopal, Brookline, MA (from 1983, bearing the Bozeman-Gibson style), and The Eliot Congregational Church, Newton, MA (1987, bearing the Bozeman name). The Bacon *Trumpet Tune* and the Cook *Alles ist* are recorded at The Eliot Church; the remainder of the recording was done at St. Paul's. While The Eliot Church appears to have a more independent pedal, the stoplists (and sounds) are virtually identical, and the rooms sound not unlike each other: pleasantly resonant if not reverberant. Both organs have strong personalities and are wonderfully colorful. The St. Paul's instrument has a grand Pedal trombone, a liquid stopped diapason (that Ms. Metson uses to wonderful effect in *Cabin in the Rain*), a floating celeste, a luscious tremulant, and a splendid, ringing chorus. The Eliot Church trumpet is perhaps not entirely equal to the challenge of Bacon's *Trumpet Tune*, which seems to suggest a more commanding effect.

It's an ingratiating recording, highly recommended for Ms. Metson's interpretation of *Spirits and Places* and the engaging organs recorded. I would pity a broadcaster, though, who based a broadcast on the timings shown on the box: the durations of the last four works are wrong, one by as much as eight minutes!

—Kenneth Matthews
San Francisco, CA

Canterbury Carols. The Choir of Canterbury Cathedral; David Flood, Organist and Choir Master; Michael Harris, Assistant Organist. York Ambisonic CD 109. (Compact disc. DDD. Stereo/Ambisonic UHJ surround-sound. TT=59:50)

"O Come, All Ye Faithful," "Sussex Carol," "Stille Nacht," "Once in Royal David's City," "Ding Dong! Merrily on High," "Candlelight Carol," "God Rest Ye Merry, Gentlemen," "The Three Kings," "O Little Town of Bethlehem," "Good King Wenceslas," "The Little Road to Bethlehem," "Gaudete, Christus Est Natus," "In the Bleak Midwinter," "While Shepherds Watched," "Away in a Manger," "Hark! The Herald Angels Sing." Dubois: *Toccata*.

York Ambisonic's admirable survey of British cathedral choirs and organs brings us a very traditional carol program from the heart of the Church of England. Most of the carols are presented in familiar Oxford University Press arrangements, and the newer items—John Rutter's "Candlelight Carol" and Michael Head's "The Little Road to Bethlehem"—nestle pastorally among their venerable companions. The choral performances are immaculate and reserved. The surround-sound recording produces a natural enough result in standard stereo playback, but the balances very much favor the boys over the lower voices. Prototypical.

A Longwood Gardens Christmas. Michael Stairs, organ. Direct-to-Tape DTR9102CD. (Compact Disc. DDD. TT=58:09) Available from Direct-To-Tape Recording Co., 14 Station Avenue, Haddon Heights, NJ 08035.

19 popular selections: "Santa Claus is Coming to Town," "The Christmas Song," "I Saw Mommy Kissing Santa Claus," "Jingle Bells," "Rudolph the Red-Nosed Reindeer," "Silver Bells," "White Christmas," and others. Stairs: *Variations on "Adeste Fidelis";* Manz: *Choral Improvisation on "In Dulci Jubilo";* Cook, *Paeon on "Divinum mysterium."*

'Twas the night before the Fourth of July, and on the hottest night of the year I was trying to make myself sit down to review this record. This seasonal incongruity was neither improving my mood nor dispelling my basic distrust of organ pops programs. But I settled down to work anyway, only to discover that no one could possibly stay grumpy while listening to this disc. Heat, humidity, and curmudgeonry temporarily banished, there was, for a few minutes, Christmas in July.

Michael Stairs, official organist of the Philadelphia Orchestra, knows an important secret: When you have a good

tune, don't get in its way! These familiar melodies are never overdressed, but the settings are consistently imaginative and colorful. The large organ (eight divisions, including a percussion section) at Philadelphia's Longwood Gardens, built by Aeolian in 1930, provides Mr. Stairs with a colorful period palette ranging from churchly to theatrical. An especially wonderful moment comes in Mel Tormé's "The Christmas Song" when the melody, on various solo flutes and reeds, is accompanied by the piano stop in a closed expression box. The effect is that of music remembered, coming from out of the past rather than from behind the swell shutters.

The pops items are also available on the cassette and digital audio tape *Christmas Pops at Longwood Gardens* (DTR8705). In addition, the CD contains concert works by Paul Manz, John Cook, and Mr. Stairs previously released on the cassette/DAT *Christmas at Longwood Gardens* (DTR8511). These pieces are of more austere lineage than their discmates but certainly joyous and no less approachable. The producers are to be commended for taking advantage of the compact disc's time capabilities, but collectors of all formats should be aware of duplication or omission possibilities.

Here is a full measure of nostalgia, sentiment, and fun wrapped up in an elegantly musical Christmas package. Recommended for holiday listening and maybe even the occasional hot summer night . . .

—Randy L. Neighbarger
Durham, NC

Lemare Affair "II"—Concert Organ Works by the Victorian Virtuoso Edwin H. Lemare and His Contemporaries—The Mighty Kotschmar Memorial Organ, Portland City Hall, Portland, Maine—organist Frederick Hohman. Pro Organo CD 7018 [DDD]. Total playing time 72:22. Available from Pro Organo Direct Sales, P.O. Box 6494, South Bend, IN 46660-6494. Tel. 800/336-2224. \$15 postpaid.

Lemare: *Fantaisie Fugue*, Opus 48; *Marche Heroique*, Opus 74; *Rhapsody*, Opus 43; *Scherzo Fugue*, Opus 102; *Concert Fantasia and Variations on "Hanover,"* Opus 4; "O Star of Eve" from Wagner's *Tannhäuser* (arrangement). William Wolstenholme: *The Seraph's Strain; Le Carillon; The Question & The Answer.* Alfred Hollins: *Allegretto grazioso; Morceau de Concert en Forme de Valse.*

This disc proves once more not only the validity of symphonic organ repertoire as legitimate concert fare, but also that Frederick Hohman is one of the symphonic organ's strongest exponents. Here we have an intact symphonic organ (Austin Opus 323, 1912, enlarged in 1927) on which Lemare himself once performed, the literature which it inspired, and an equally inspired artist, drawing the literature to life as he

exhausts every combination and shading of color imaginable from the Austins' 6564 pipes. This disc reminds us well how the symphonic organ could enjoy such popularity. Hohman's readings are never cool or distant. Rather, his playing is free, passionate, heart-filled, and entirely convincing throughout.

This CD focuses on five concert pieces of Edwin Lemare, all of which date prior to his Portland years. The high drama of the opening *Fantaisie Fugue*, Opus 48 (it alone worth the price of the CD) demonstrates Hohman's no-nonsense technical command. Unlike Hohman's original *Lemare Affair* recording (Pro Organo CD7007), which was the first all-Lemare recording to appear, in 1987, this sequel CD also spotlights six miniatures by two of Lemare's most notable cohorts: Alfred Hollins and William Wolstenholme. It is in these works that Hohman has contributed some of the most expressive and stylish playing this reviewer has heard, either on record or in live concert. He appears to shape lines by balancing timing, rubato and dynamic shadings against a technique, obviously exploited during the symphonic age, which encourages accentuating notes through lengthening the dwell within a phrase rather than upon relying solely upon delays (agogic accents). Just as the late Virgil Fox so well demonstrated, Hohman can and does bend a line anywhere he jolly well wants it!

The 16-page booklet holds complete organ specifications and an engagingly written essay on the composers and their works. Of all recent recordings of the Kotschmar organ, this is the one which best captures the full depth of the auditorium. It also showcases the organ handsomely, as, with the exception of the first two tracks, the recording was made following extensive maintenance, finished in the Spring of 1992, which served to restore some of the organ's most imposing solo division stops and pedal reeds.

—Bernard Durman
Loveland, OH



THE CANTERBURY COLLECTION

FIVE CANTERBURY CATHEDRAL CHOIR AND ORGAN COMPACT DISCS OR CHROME CASSETTES.

FREE CATALOG FROM:

BRENDAN HEARNE,
YORK AMBISONIC (DIAP.),
PO BOX 66, LANCASTER,
ENGLAND LA2 6HS.

fine leather shoes for organists Organmaster Shoes



Fast UPS Delivery

WOMEN'S, 3 Colors, Sizes 4-11, \$36 ppd.
MEN'S, Black, Sizes 6-12, \$44 ppd.
Sizes 12½-13, \$48 ppd., Sizes 14-16, \$53 ppd.
Narrow, Medium and Wide widths
CALL OR WRITE (203)-453-1973

282 Stepstone Hill, Guilford, CT 06437



Faucher Organ Company

441 Main St. Biddeford, ME 04005

- Affordable New Instruments
- Rebuilding & Restoration
- Professional Maintenance

Robert R. Faucher 1-800-370-PIPE

PAUL FRITTS & CO.

ORGANBUILDERS

630 East 121st Street
Tacoma, WA 98445-3030
(206) 535-3374

NICHOLS & SIMPSON, INC.
ORGANBUILDERS
P.O. BOX 7375
LITTLE ROCK, ARKANSAS 72217
501-661-0197
YOUR INQUIRIES CORDIALLY INVITED
C. JOSEPH NICHOLS WAYNE E. SIMPSON, III
PRESIDENT VICE-PRESIDENT
501-758-6904 501-372-5111

martin ott pipe organ company inc.
1353 Baur Boulevard
St. Louis Missouri 63132
(314) 569-0366

Scott R. Kiedel
CONSULTANT IN ECCLESIASTICAL
ACOUSTICS, MUSIC & ARCHITECTURE
11040 West Blenheim Road, Wausau, Wisconsin 53226
(414) 771-8966



WALKER

J.W. Walker & Sons Ltd.

Brandon, Suffolk, England.

Makers of fine Tracker Action organs
in the best English tradition.

Call our Cincinnati office for brochure: 1-800 628 3275

By Appointment to Her Majesty Queen Elizabeth II
Pipe Organ Builders and Tuners

Scaling Organ Pipes— with a Computer

Herbert L. Huestis & Warren P. Huestis

One very useful computer program for organ builders is the spreadsheet. This electronic marvel can be tailored to a pipe maker's needs to calculate scales and interpolate measurements of length, diameter, cutup of the pipe mouth, metal thicknesses and a host of other information that is needed to carry out the art of pipe making. Until the personal computer appeared on the scene, this kind of work was done with measuring sticks, graph paper, pencil and a big eraser. Now, numbers may be crunched in the computer before any metal is cut on the workbench. Most organbuilding applications involve the use of simple formulas and basic trigonometry—the computer spreadsheet works like a programmable calculator.

It is fairly easy to master the fundamentals of spreadsheet formulas, even for those who do not consider themselves "computer literate." No special "language" or programming skills are necessary. The rows and columns of a spreadsheet are organized like an accounting ledger. Formulas are entered into "cells" where these rows and columns intersect.

Spreadsheets such as *Microsoft Excel*, *Lotus 1-2-3* or *Borland Quatro* share many features and generally work the same way. For these examples, I have used a *Lotus 1-2-3* "look-alike" program called *ASEASY*, which is a 'shareware' program. (*ASEASY* is distributed by Trius, Inc., Suite 2D-3, 231 Sutton St., North Andover, MA 01845.)

Almost any computer can run a spreadsheet, and most programs will do the job as long as they offer trigonometric functions. Pipe scale spreadsheets require only a moderate degree of sophistication from software, hardware, and most importantly, the user.

Getting Started

Think of an electronic spreadsheet as a two-dimensional checkerboard of rows and columns that works in the computer's memory. Generally, rows are identified by numbers and columns by letters. The intersections of these rows and columns are called "cells." Finding a cell is like looking up the distance from Salt Lake City to St. Louis on a mileage chart. To run a spreadsheet, you point to these cells and tell the computer what you want to happen in them. You may enter numbers directly, or use a formula and let the computer put in the numbers. When cells are named in formulas, the computer "calls up" the contents of these cells. That's just about all there is to it!

The samples presented here stick to simple calculations. Even so, the old computer cliché applies: GIGO (Garbage In, Garbage Out). Spreadsheets are no exception!

Formulas

Spreadsheet commands are very straightforward and take relatively little time to learn. The reward is that the computer enables you to work with data in ways that will give you new insights and flexibility. As you design formulas to extract information from your data, you will become a better organizer and a little bit better thinker. For most of us, that's a welcome accomplishment!

Spreadsheet formulas are entered with basic arithmetic operators like +, -, % and =. Instructions may range from simple arithmetic to calculations based on values of other cells. It is a daisy-chain where cells are inserted, deleted, copied or moved and formulas adjusted and recalculated as they go. When you catch on to it, you can make up a "program" that will perform a multitude of calculations.

Here are some examples that show how spreadsheet formulas work:

1) $2 + 6 * 2 = 14$

In the mathematical hierarchy, multiplication comes before addition, so 6 is multiplied by 2; then the product of 12 is added to 2, for a result of 14.

2) $(2 + 6) * 2 = 16$

Values within parentheses are calculated first: 2 is added to 6; then the result multiplied by 2, giving a product of 16.

3) $A1 + A2$

This formula adds the contents of two cells—A1 and A2. If this formula is entered at the location of cell C7, the result will appear there. Whenever you go to cell C7, you will see the entry as a formula—but in the video spreadsheet, you will see the calculated value. If the contents of either A1 or A2 are changed, the value displayed in C7 will also change.

4) $@SQRT((B1 + 44)/2) = 5.148$ (Cell B1 = 9)

Here, 44 is added to the contents of cell B1. The result is then divided by 2. Then the square root is calculated for the entire value.

Checking Parentheses

Spreadsheets will not accept the entry of a formula unless beginning and ending parentheses are matched. (They automatically revert to the edit mode.) A good way to check parentheses is to draw a line between each set to verify that they match. A 'parentheses check' would look like this:

$$@SQRT((C22*C22) - (((3/2)^(A22 - B22)) * ((3/2)^(A22 - B22))))$$

Herbert L. Huestis, Ph.D., holds a music degree from the Eastman School of Music, University of Rochester, where he was a student of David Craighead. His graduate study was in psychology and education from the University of Idaho. He is a pipe organ technician in the Pacific Northwest, where he and his wife specialize in careful renovations and restorations of old organs.

Warren P. Huestis is a third-year student at Simon Fraser University in Vancouver, British Columbia, where he majors in computer science. He has been involved with pipe organs from the time he could pick up a screw driver. He is a professional chorister in Vancouver and has combined his interests in math, computing and music throughout his college career.

A quick way to see if parentheses match is to count all the left-handed parentheses and see if they add up to the same total as the right-handed parentheses. If they are equal, all is well.

Trigonometric Functions

Most spreadsheets have a complete set of trigonometric functions. These are a means of measuring angles and finding lengths of sides of triangles. These functions are generally used in surveying, navigation and describing phenomena such as sound waves.

Radian and Degree Measurements

Angles may be measured in degrees or radians. Degree measurements (like those made with a protractor) are the most commonly used. In radian measurement, the circumference of a circle is divided into units of an arc, each having a length equal to its radius. This makes a total circumference of 2π or 6.28 unit arcs. The number of radian arcs intercepted by a central angle is the measure of the angle in radians.

The measurement of an angle may be converted from radians to degrees. That equation is expressed by these two formulas:

$$M_{deg} = \left[\frac{180}{\pi} \right] M_{rad} = 57.32484 \sigma$$

$$M_{rad} = \left[\frac{180}{\pi} \right] M_{deg} = .017444$$

Writing Spreadsheet Formulas

Each trigonometric function is followed by parentheses which identify the operands. Values within parentheses are also referred to as *arguments* of each function. Here is a list of functions and their arguments:

ACOS (cosine value)	Returns the angle in radians
ASIN (sine value)	" "
ATAN (tangent value)	" "
COS (radian angle)	Returns cosine
SIN (radian angle)	Returns sine
TAN (radian angle)	Returns tangent
PI (no argument)	Returns the value of the constant π
*180/PI	Converts an angle in radians to an angle in degrees

Since these spreadsheet commands compute values in radians, the answer is multiplied by $180/\pi$ to obtain the answer in degrees. For example, the value of $ACOS(.33)$ is 1.234492 radian units or approximately 71 degrees.

Applications

Interpolating Pipe Scales From Samples

Here are some examples, taken from pipe scaling spreadsheets. Dimensions of organ pipes follow a logarithmic curve—a mathematical progression where the value of each successive pipe is based on the measurement of the preceding pipe. To interpolate data for a rank of pipes from a few samples, a factor may be found and applied to the interval from one sample to another. Here is the formula for an ascending interval of one octave:

$$N_{1..n} \cdot [(N_2/N_1) \cdot x^{(i-1)/i}] = N_{2..n}$$

In this formula,
 $N_{2..12}$ = numbers which are interpolated
 $N_{1..n}$ = preceding numbers in series
 N_{13} = highest number in interval (sample 1)
 N_1 = lowest number in interval (sample 2)
 x^i = exponential function on any calculator (\wedge in spreadsheets)
 $1/i$ = fractional value of exponent

The same formula may be used for interpolations in a descending interval. In this case, successive values are divided by the same logarithmic factor. You may calculate these values, using a scientific calculator with constant (k) and exponential

Pipe	Number	Formula	Pipe length in inches
C	1	(first sample)	= 48.0
C#	2	$N_1 / [(N_1/N_{13}) \cdot x^{(1/12)}] = 45.3$	
D	3	$N_2 / [(N_1/N_{13}) \cdot x^{(2/12)}] = 42.76$	
D#	4	$N_3 / [(N_1/N_{13}) \cdot x^{(3/12)}] = 40.36$	
E	5	$N_4 / [(N_1/N_{13}) \cdot x^{(4/12)}] = 38.1$	
F	6	$N_5 / [(N_1/N_{13}) \cdot x^{(5/12)}] = 35.96$	
F#	7	$N_6 / [(N_1/N_{13}) \cdot x^{(6/12)}] = 33.94$	
G	8	$N_7 / [(N_1/N_{13}) \cdot x^{(7/12)}] = 32.04$	
G#	9	$N_8 / [(N_1/N_{13}) \cdot x^{(8/12)}] = 30.24$	
A	10	$N_9 / [(N_1/N_{13}) \cdot x^{(9/12)}] = 28.41$	
A#	11	$N_{10} / [(N_1/N_{13}) \cdot x^{(10/12)}] = 26.94$	
B	12	$N_{11} / [(N_1/N_{13}) \cdot x^{(11/12)}] = 25.43$	
C	13	(second sample)	= 24.0

(x^r) functions. Try a descending interval of one octave, where the first note is 4' long and the 13th note is 2' long.

Here are the same formulas in a spreadsheet:

A	B	C	(formulas in column C)
1	SPREADSHEET NO. 1: INTERPOLATING DATA		
2			
3	Pipe	Number	Pipe Length (")
4			
5	C	1	48 (first sample)
6	C#	2	+C5/(C5/C17)^(1/12)
7	D	3	+C6/(C5/C17)^(1/12)
8	D#	4	+C7/(C5/C17)^(1/12)
9	E	5	+C8/(C5/C17)^(1/12)
10	F	6	+C9/(C5/C17)^(1/12)
11	F#	7	+C10/(C5/C17)^(1/12)
12	G	8	+C11/(C5/C17)^(1/12)
13	G#	9	+C12/(C5/C17)^(1/12)
14	A	10	+C13/(C5/C17)^(1/12)
15	A#	11	+C14/(C5/C17)^(1/12)
16	B	12	+C15/(C5/C17)^(1/12)
17	C	13	24 (second sample)

In this example, the value of the first sample is entered in column C, Row 5. This number is referenced in each of the formulas which follow. The value of the second sample is entered in column C, Row 17. The notation C5/C17^(1/12) represents the logarithmic factor which is applied to each descending number of the interval.

Formulas for Pipe Making

Making Cone Patterns

There are many uses for this type of scaling spreadsheet—making pipe feet and reed resonators, for example. To give a clear picture of this process, we'll begin with the drawing of the conical portion of an 8' trumpet (note C 37) in Figure 1.0. Dimensions are in millimeters:

Figure 1.0

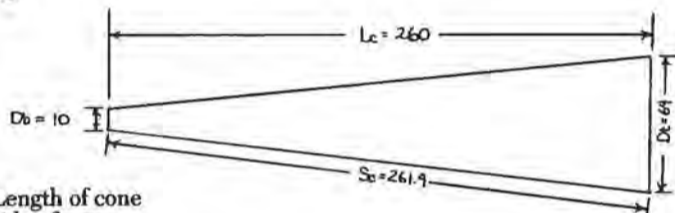

Lc = Length of cone
Sc = Side of cone
Db = Diameter at bottom
Dt = Diameter at top

This same pipe resonator is now shown as a flat pattern in Figure 2.0.

Figure 2.0

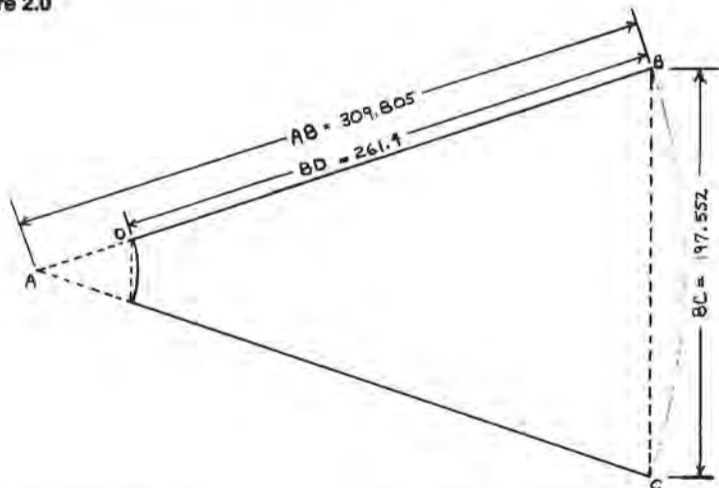

To make the pattern, a pipemaker first lays out a radial line AB. We might think of this as the left side of a piece of pie. Next, an arc is drawn from point B. This arc would be analogous to the pie crust. Then a chord BC is drawn from the end of the radial line, so that both ends touch the arc (or "pie crust"). (The length of the arc BC is equal to the circumference of the finished cone.) Points A and C are then joined with a second radial line to make the other side of the cone pattern. Finally, side BD is measured along line AB and a bottom arc is scribed from point D to point E on line AC. (Now the pattern looks like someone has taken a bite out of your piece of pie.) This completes the pipe pattern.

In our examples, these figures are given for a typical cone:

1. Top diameter (Dt) = 64 mm
2. Bottom diameter (Db) = 10 mm
3. Length (Lc) = 260 mm
4. Side (Sc) = 261.4 mm

The following values are then calculated to make a pattern. Each formula finds its way into the next, so they are presented in sequential order:

1. Solve for BD: the side of the cone.
2. Solve for AB: the radial line which forms the side of the cone pattern.
3. Solve for BC: the chord which denotes the length of the top arc of the cone pattern.

These formulas are presented in mathematical terms, then followed with the

equivalent spreadsheet notation. A final version shows cell addresses as they appear in the actual spreadsheet.

Formula 2.1 calculates the side of the cone:

$$Sc = \sqrt{Lc^2 + \left[\frac{Dt - Db}{2} \right]^2}$$

$$= \sqrt{260^2 + \left[\frac{64 - 10}{2} \right]^2} = 261.398$$

Putting this formula in spreadsheet notation, it would appear this way:

$$SQRT((Lc^2) + ((Dt - Db)/2)^2)$$

With cell addresses:

$$@SQRT((C10^2) + ((A10 - B10)/2)^2)$$

Formula 2.2 calculates the radial line AB of a cone pattern:

$$R = \frac{Dt \cdot Sc}{Dt - Db} = \frac{64(261.3)}{64 - 10} = 309.805$$

In spreadsheet form it will have this notation:

$$Dt * Sc / (Dt - Db)$$

Here it is with cell addresses:

$$A10 * C10 / (A10 - B10)$$

Formula 2.3 calculates the chord which defines the length of the top arc of the cone pattern:

$$\text{Chord } BC = 2R \sin \left[\pi \frac{Dt}{2R} \right] = 2(309.805) \sin \left[\pi \frac{64}{2(309.805)} \right] = 197.552$$

This formula changes very little in spreadsheet notation:

$$2 * R * SIN((PI * Dt / (2 * R)))$$

With cell addresses:

$$2 * F19 * @SIN((@PI * A10 / (2 * F19)))$$

These formulas are incorporated in Spreadsheet No. 2:

A	B	C	D	E	(formulas in column E)
1	SPREADSHEET NO 2: MAKING CONE PATTERNS				
2					
3	KNOWN VALUES: top diameter, bottom diameter and length.				
4					
5					
6	2.1	SOLVE FOR:	SIDE (line BD) of cone pattern		
7					
8	Dt	Db	Lc	Th S (Side)	(formula)
9					
10	64	10	260.000	0.0	261.398 @SQRT((C10^2) + ((A10 - D10) - (B10 - D10)) / 2)^2)
11					
12					
13	2.2	SOLVE FOR:	RADIUS (line AB) of cone pattern		
14					
15				R (Radius)	(formula)
16					
17				309.805	+E10*(A10 - D10) / ((A10 - D10) - (B10 - D10))
18					
19					
20	2.3	SOLVE FOR:	CHORD (line BC) of cone pattern		
21				Ch (Chord)	(formula)
22					
23				197.552	2 * E17 * @SIN((@PI * (A10 - D10) / (2 * E17)))
24					
25					
26					
27	Note: Metal thickness may be entered if exact fit is required.				

Determining the Angle of a Conical Pipe

The next set of formulas may be used for making pipe mandrels. These are wood or metal forms that are used to mold organ pipes to a conical shape. In this application, the bottom diameter is something between 5 and 10 mm, depending on the size of the mandrel and the convenience of lathing wood or metal stock down to a very small diameter. Mandrels are designated by their cone angles. These figures may be calculated right along with other pipe scaling data.

Another application for the calculation of cone angles is the fitting of telescopic pipe sections for large pipes or making sockets to receive the tip of reed resonators. Formula 3.1 solves for cone angle (>cn) with input values (in mm.) for top diameter (Dt), bottom diameter (Db), and length of the cone (Lc):

$$>cn = \arctan \left[\frac{Dt - Db}{2Lc} \right]$$

$$= \arctan \left[\frac{64 - 10}{2(260)} \right] = 5.93$$

In spreadsheet notation:

$$@ATAN((Dt - Db) / (2 * Lc)) * 180 / @PI$$

and written with cell addresses:

$$@ATAN((B16 - A16) / (2 * C16)) * 180 / @PI$$

If the length of the side is known (rather than height) Formula 3.2 is used to calculate the cone angle. Input values are top diameter (Dt), bottom diameter (Db) and side (Sc).

$$<cn = \arcsin \left[\frac{Dt - Db}{2Sc} \right]$$

$$= \arcsin \left[\frac{64 - 10}{2(261.3)} \right] = 5.92$$

Here is the spreadsheet notation:

$$@\text{ASIN}((\text{Dt} - \text{Db}) / (2 * \text{Sc})) * 180 / @\text{PI}$$

and cell addresses:

$$@\text{ASIN}((\text{B10} - \text{A10}) / (2 * \text{C10})) * 180 / @\text{PI}$$

These formulas are incorporated into *Spreadsheet No. 3*:

A	B	C	D	(formulas in column D)
1	SPREADSHEET NO. 3: MAKING PIPE HANDRELS			
2	KNOWN VALUES: top diameter, bottom diameter and length or side.			
3				
4				
5				
6	3.1	SOLVE FOR:	CONE ANGLE with known top diameter, bottom diameter and length of cone.	
7				
8				
9	Dt	Db	Lc	>cn (computation in radians--result in degrees)
10	64	10	260.000	5.929 @ATAN((A11-B11)/(2*C11))*180/@PI
11				
12				
13				
14	3.2	SOLVE FOR:	CONE ANGLE with known top diameter, bottom diameter and side of cone.	
15				
16				
17	Dt	Db	Sc	>cn (computation in radians--result in degrees)
18	64	10	261.398	5.929 @ASIN((A19-B19)/(2*C19))*180/@PI
19				

It is very useful to be able to calculate the diameter at any point along a cone. A number of applications come to mind, including making telescopic sections of large resonators and sockets that are a precise fit. Another application is calculating the size of rack boards for reed pipes and even figuring the offset when reed pipes lean "off center" in their rack boards. In that case you are not figuring "top diameter," but the distance across the top of the angle formed between a perpendicular line above the pipe foot and the centerline of each resonator in its "leaning" state.

Formula 4.1 calculates the diameter at any point along a conical resonator. Input values are given in mm, for tip diameter, cone angle and side.

$$\text{Dt} = 2 \text{Sc} \cdot \arcsin > \text{cn} + \text{Db} \\ = 2(261.3) \cdot \arcsin 5.93 + 10 = 64$$

As written in a spreadsheet:

$$(2 * \text{Sc}) * @\text{ASIN}(< \text{cn} * @\text{PI} / 180) + \text{Db}$$

With cell addresses:

$$(2 * \text{A10}) * @\text{ASIN}(\text{C10} * @\text{PI} / 180) + \text{B10}$$

If you are working with pipe scales, formula 4.2 will solve for top diameter or resonator offset with the given values of cone angle, tip diameter and length (or height) of the cone.

$$\text{Dt} = \tan < \text{cn} * 2 \text{Lc} + \text{Db} \\ = \tan 5.93 * 2(260) + 10 = 64$$

In spreadsheet notation:

$$@\text{TAN}(< \text{cn} * @\text{PI} / 180) * (\text{Lc} * 2) + \text{Db}$$

With cell addresses:

$$@\text{TAN}(\text{E37} * @\text{PI} / 180) * (\text{C37} * 2) + \text{F37}$$

These formulas are incorporated into *Spreadsheet No. 4*:

A	(formulas entered in column A)	B	C	D
1	SPREADSHEET NO. 4: TOP OR MID-POINT DIAMETERS; OFFSET DISTANCES; MAKING BACKBOARDS (Note: Db may be zero)			
2				
3				
4				
5	4.1	SOLVE FOR:	TOP DIAMETER with known angle, bottom diameter and side of cone.	
6				
7				
8	Dt/m		Db	Sc <cn
9				
10	64.0	2*DI0*@SIN(E10*@PI/180)+C10	10	261.398 5.929
11				
12				
13	4.2	SOLVE FOR:	TOP DIAMETER with known angle, bottom diameter and length of cone.	
14				
15				
16	Dt/m (or offset from perpendicular)		Db	Lc <cn
17				
18	64.0	@TAN(E18*@PI/180)*(D18*2)+C18	10	260.000 5.929

Sample Spreadsheets

In the following pipe scale worksheet, these formulas are applied:

- 1.1. Interpolation of pipe scales from samples.
- 2.1. Calculation of the side of a cone.
- 2.2. Calculation of the radius of a cone pattern.
- 2.3. Calculation of the top chord of a cone pattern.
- 3.1. Calculation of a cone angle.

Sample data are entered for C's marked with brackets, i.e., {C}. The other notes are interpolated. (Samples may be entered for notes other than "C's" and top "G.") To adjust the size of the interpolation interval, change the step-wise fraction of 1/12. For example, to interpolate an interval of 8 notes (seven steps), use a fraction of 1/7 in the interpolation formula.

The second example is a one-octave section of the same spreadsheet with the formulas rather than the computed values displayed.

Acknowledgements

Martin Pasi, organ builder, for his assistance in verifying formulas, spreadsheets, and pipemaking instructions.

SCALES..... Pipe Making.....

Note	Dt	Db	Lc (res)	Thk	Circ
1 { C }	132	16	2260	1.0	+C17*8PI
2 C#	+C17/(C#17/C#29)^(1/12)	+D17/(D#17/D#29)^(1/12)	+E17/(E#17/E#29)^(1/12)	+F17/(F#17/F#29)^(1/12)	+C18*8PI
3 D	+C18/(C#17/C#29)^(1/12)	+D18/(D#17/D#29)^(1/12)	+E18/(E#17/E#29)^(1/12)	+F18/(F#17/F#29)^(1/12)	+C19*8PI
4 D#	+C19/(C#17/C#29)^(1/12)	+D19/(D#17/D#29)^(1/12)	+E19/(E#17/E#29)^(1/12)	+F19/(F#17/F#29)^(1/12)	+C20*8PI
5 E	+C20/(C#17/C#29)^(1/12)	+D20/(D#17/D#29)^(1/12)	+E20/(E#17/E#29)^(1/12)	+F20/(F#17/F#29)^(1/12)	+C21*8PI
6 F	+C21/(C#17/C#29)^(1/12)	+D21/(D#17/D#29)^(1/12)	+E21/(E#17/E#29)^(1/12)	+F21/(F#17/F#29)^(1/12)	+C22*8PI
7 F#	+C22/(C#17/C#29)^(1/12)	+D22/(D#17/D#29)^(1/12)	+E22/(E#17/E#29)^(1/12)	+F22/(F#17/F#29)^(1/12)	+C23*8PI
8 G	+C23/(C#17/C#29)^(1/12)	+D23/(D#17/D#29)^(1/12)	+E23/(E#17/E#29)^(1/12)	+F23/(F#17/F#29)^(1/12)	+C24*8PI
9 G#	+C24/(C#17/C#29)^(1/12)	+D24/(D#17/D#29)^(1/12)	+E24/(E#17/E#29)^(1/12)	+F24/(F#17/F#29)^(1/12)	+C25*8PI
10 A	+C25/(C#17/C#29)^(1/12)	+D25/(D#17/D#29)^(1/12)	+E25/(E#17/E#29)^(1/12)	+F25/(F#17/F#29)^(1/12)	+C26*8PI
11 A#	+C26/(C#17/C#29)^(1/12)	+D26/(D#17/D#29)^(1/12)	+E26/(E#17/E#29)^(1/12)	+F26/(F#17/F#29)^(1/12)	+C27*8PI
12 B	+C27/(C#17/C#29)^(1/12)	+D27/(D#17/D#29)^(1/12)	+E27/(E#17/E#29)^(1/12)	+F27/(F#17/F#29)^(1/12)	+C28*8PI
13 { C }	95	14	1105	.9	+C29*8PI

The formulas in each column are:
Dt = top diameter
Db = bottom diameter
Lc(res) = length of resonator
Thk = thickness of metal
Circ = circumference of resonator
Side = side of cone
Rad = radius of arc for cone pattern
Chord = chord of arc for cone pattern
Cn = angle of cone
(Data entered on rows 1 and 13)

Side	Rad	Chord	<Cn
@SQRT((E17^2)+((C17-F17)-(D17-F17))/2)^2)	+H17*(C17-F17)/((C17-F17)-(D17-F17))	2*I17*8SIN((@PI*(C17-F17)/(2*I17)))	BATAN((C17-D17)/(2*E17))*180/@PI
@SQRT((E18^2)+((C18-F18)-(D18-F18))/2)^2)	+H18*(C18-F18)/((C18-F18)-(D18-F18))	2*I18*8SIN((@PI*(C18-F18)/(2*I18)))	BATAN((C18-D18)/(2*E18))*180/@PI
@SQRT((E19^2)+((C19-F19)-(D19-F19))/2)^2)	+H19*(C19-F19)/((C19-F19)-(D19-F19))	2*I19*8SIN((@PI*(C19-F19)/(2*I19)))	BATAN((C19-D19)/(2*E19))*180/@PI
@SQRT((E20^2)+((C20-F20)-(D20-F20))/2)^2)	+H20*(C20-F20)/((C20-F20)-(D20-F20))	2*I20*8SIN((@PI*(C20-F20)/(2*I20)))	BATAN((C20-D20)/(2*E20))*180/@PI
@SQRT((E21^2)+((C21-F21)-(D21-F21))/2)^2)	+H21*(C21-F21)/((C21-F21)-(D21-F21))	2*I21*8SIN((@PI*(C21-F21)/(2*I21)))	BATAN((C21-D21)/(2*E21))*180/@PI
@SQRT((E22^2)+((C22-F22)-(D22-F22))/2)^2)	+H22*(C22-F22)/((C22-F22)-(D22-F22))	2*I22*8SIN((@PI*(C22-F22)/(2*I22)))	BATAN((C22-D22)/(2*E22))*180/@PI
@SQRT((E23^2)+((C23-F23)-(D23-F23))/2)^2)	+H23*(C23-F23)/((C23-F23)-(D23-F23))	2*I23*8SIN((@PI*(C23-F23)/(2*I23)))	BATAN((C23-D23)/(2*E23))*180/@PI
@SQRT((E24^2)+((C24-F24)-(D24-F24))/2)^2)	+H24*(C24-F24)/((C24-F24)-(D24-F24))	2*I24*8SIN((@PI*(C24-F24)/(2*I24)))	BATAN((C24-D24)/(2*E24))*180/@PI
@SQRT((E25^2)+((C25-F25)-(D25-F25))/2)^2)	+H25*(C25-F25)/((C25-F25)-(D25-F25))	2*I25*8SIN((@PI*(C25-F25)/(2*I25)))	BATAN((C25-D25)/(2*E25))*180/@PI
@SQRT((E26^2)+((C26-F26)-(D26-F26))/2)^2)	+H26*(C26-F26)/((C26-F26)-(D26-F26))	2*I26*8SIN((@PI*(C26-F26)/(2*I26)))	BATAN((C26-D26)/(2*E26))*180/@PI
@SQRT((E27^2)+((C27-F27)-(D27-F27))/2)^2)	+H27*(C27-F27)/((C27-F27)-(D27-F27))	2*I27*8SIN((@PI*(C27-F27)/(2*I27)))	BATAN((C27-D27)/(2*E27))*180/@PI
@SQRT((E28^2)+((C28-F28)-(D28-F28))/2)^2)	+H28*(C28-F28)/((C28-F28)-(D28-F28))	2*I28*8SIN((@PI*(C28-F28)/(2*I28)))	BATAN((C28-D28)/(2*E28))*180/@PI
@SQRT((E29^2)+((C29-F29)-(D29-F29))/2)^2)	+H29*(C29-F29)/((C29-F29)-(D29-F29))	2*I29*8SIN((@PI*(C29-F29)/(2*I29)))	BATAN((C29-D29)/(2*E29))*180/@PI



Cover

John-Paul Buzard Organ Craftsmen, Inc., Champaign, IL, has built a new organ, opus 9, for Southminster Presbyterian Church, Arlington Heights, IL. The 22-stop, 29-rank organ is located in the rear balcony of the sanctuary. The free-standing case and console are of white oak with walnut accents, finished in clear lacquer. The Great is located at the top of the case with the Swell below and the Pedal divided on either side. Front pipes of 75% English tin are from the Great Principal 8' and Pedal Octave 8'; wooden front pipes from the Great/Pedal Gedeckt Pommer 16' are made of Honduras mahogany, stained with a red aniline dye. The case stands about 25 feet high, and measures 22 feet wide and 5 feet deep.

The organ utilizes electric-slider action, in deference to the church's desire to move the console from time to time. Great and Pedal are voiced on 3½ inches, Swell on 4 inches, and the low 18 notes of the Pedal Posaune on 4½ inches. Console registration is by drawknobs, located in terraces on either side of the manual keyboards; interdivisional couplers, also drawknobs, are located on the nameboard. Pedal drawknobs are of ebony, manual drawknobs of walnut, and coupler drawknobs cocobolo of the firm's own design. Compass 61/32.

GREAT

- 16' Gedeckt Pommer
- 8' Principal
- 8' Flute a Biberon
- 4' Octave
- 4' Spitz Flute
- 2' Fifteenth
- 1½' Mixture IV
- Sesquialtera II
- 8' Trompette
- 8' Trompette en Chamade (prep)

SWELL

- 8' Narrow Principal
- 8' Bourdon
- 8' Flute Celeste
- 4' Octave
- 4' Flute Harmonique
- 2' Block Flute
- 2' Plein Jeu IV
- 16' Bassoon
- 8' Trompette
- 8' Oboe (ext 16')
- Tremulant
- 8' Trompette en Chamade (prep)

PEDAL

- 32' Untersatz (elect. 1-12)
- 16' Subbass
- 16' Gedeckt Pommer (Gt)
- 8' Octave
- 8' Spitz Flute
- 8' Gedeckt Flute (Gt)
- 4' Choral Bass (ext 8')
- 16' Posaune
- 16' Bassoon (Sw)
- 8' Trumpet (ext 16')



Redman Organ Company, Fort Worth, TX, has built an organ for Texas Woman's University, Denton, TX. The instrument is located in the remodeled and modernized Margo Jones Performance Hall, and utilizes pipework from the previous 1926 Moller and 1965 Sipe-Yarbrough organs. The four-manual AGO console is provided with a Solid State Logic multiplex system. Console and casework are of white oak; manuals feature bone naturals, ebony sharps, and the Harris system of magnetic tracker touch. Drawknobs are of bone and ebony. New pipework includes a 16' Prin-

icipal with front pipes of flamed copper, Great 8' Principal, and Positiv 4' Octave; a 32' and 16' Posaune unit was built for the Pedal and a 16' Trumpet and 4' Clarion were provided for the Great and Swell respectively. Two 32' electronic extensions were placed in the Pedal. Winding is stable from large static reservoirs and in-built regulators in each main chest. Tuning is equal temperament. Dr. Thomas K. Brown, professor of music at TWU, played the inaugural recital March 22, 1991, and Marie-Claire Alain performed on February 26, 1992.

Journal of American Organbuilding

This technical journal for organbuilding professionals is also a valuable resource for consultants and musicians involved in pipe organ projects.

Please enter my subscription to the *Journal of American Organbuilding*. Enclosed is a check payable to AIO for \$12 (1 year, 4 issues) \$32 (3 years, 12 issues)

name _____
mailing address _____
city _____ state _____ zip _____

Return this form and payment to:
American Institute of Organbuilders
P.O. Box 130982, Houston TX 77219

GREAT (II)

- 16' Prestant
- 8' Principal
- 8' Harmonic Flute
- 8' Rohrflote
- 4' Octave
- 4' Spitzflote
- 2½' Quinte
- 2' Superoctave
- 1½' Mixture IV
- ½' Cymbel III
- 16' Trompeten Bass
- 8' Trompette
- 8' Trompette de Fete
- 4' Trompette de Fete
- Tremulant
- Chimes (Ch)
- Zimelstern (rev)

SWELL (III)

- 16' Viole
- 8' Principal
- 8' Viole
- 8' Voix Celeste
- 8' Bourdon
- 4' Octave
- 4' Waldflote
- 2½' Nazard
- 2' Blockflote
- 2' Mixture IV
- 16' Basson
- 8' Trompette
- 8' Hautbois
- 8' Regal
- 4' Clarion
- Tremulant

CHOIR (I)

- 16' Quintadena
- 8' Principal
- 8' Gedeckt
- 8' Quintadena
- 8' Flauto Dolce
- 8' Dolce Celeste
- 4' Octave
- 4' Rohrgedeckt
- 2½' Nasat
- 2' Flachflote
- 1¾' Terz
- 1' Sifflole
- 1' Mixture IV
- 8' Fagott
- 8' Trompette de Fete (Gt)
- Tremulant
- Chimes

POSITIV (IV)

- 8' Principal
- 8' Gemshorn
- 8' Holzgedeckt
- 4' Octave
- 4' Spillflote
- 2' Superoctave
- 1½' Quinte
- 2½' Sesquialtera II
- ¾' Scharf IV
- 16' Dulzian
- 8' Krummhorn
- 16' Trompette de Fete (Gt)
- 8' Trompette de Fete (Gt)
- Tremulant

PEDAL

- 32' Untersatz
- 32' Bourdon Doux
- 16' Holzprincipal
- 16' Prestant (Gt)
- 16' Viole (Sw)
- 16' Subbass
- 16' Quintadena (Ch)
- 8' Principal
- 8' Gedeckt Bass
- 4' Choralbass
- 4' Jubal Flote
- 2' Holzflote
- 2½' Mixture IV
- 32' Posaune
- 16' Posaune
- 16' Basson (Sw)
- 8' Trompette
- 4' Schalmei
- 8' Trompette de Fete (Gt)

First Lutheran Church of Waterbury, CT, last year acquired a two-manual organ from Quincy, MA, through Alan Laufman of the Organ Clearing House, for rebuilding and installation in its rear gallery. Charles McManis, Woodbury, CT, engaged by the church as consultant, designed and supervised construction of two organ chambers, revoiced and regulated old high-pressure pipe-work for 3' wind and provided a new 7-stop Organ Supply Industries Great chest. A chamber on the opposite side of the gallery houses a Möller Artiste-type Swell. An exposed Principal, formerly divided on either side of a chancel window, was reinstalled with CC and CC# chests mounted at 90 degrees, bracketed to a corner of the Great chamber. A 6' x 8' main Great tone opening is augmented by a 2' x 3' opening toward the choristers. Organ cable is long enough for placement of the Möller console anywhere in the gallery. Currently it is mounted back of choir seating, centered near the large facade window, organist facing the altar.

The Violoncello combines with the 8' Rohrflöte to provide an enclosed "principal" tone. The Austin Clarabella became a Nazard 2 3/4', and the Austin Dulciana, beginning at Tenor D#, was rescaled as the 1 1/2' in the Great Mixture. Because nameboard and combination action space initially restricted Pedal additions, preparations have been made in the solid state equipment for their later addition. The 16' Subbass rank on its original Austin toeboards, for the sake of space, has been mounted on a 6" chest well in the Great chamber. Deagan chimes transferred from the Lutheran's defunct electronic instrument now hang exposed at the back of the Swell chamber.

- GREAT**
 16' Rohrflöte (TC), 49 notes
 8' Principal
 8' Rohrflöte
 8' Violoncello
 8' Vox Celeste (CC)
 4' Octave, 12 pipes
 4' Rohrflöte, 12 pipes
 2 3/4' Nazard
 2' Super Octave, 61 notes
III Mixture (1 1/2')
 Chimes (played from separate keyboard)
- SWELL**
 8' Gedeckt
 8' Gemshorn
 4' Spitzprinzipal
 4' Gedeckt, 12 pipes
 2' Spitzoctave, 12 pipes
 1 1/2' Larigot, 8 pipes
 8' Trumpet
 4' Clarion, 12 pipes
 Tremolo
- PEDAL**
 16' Subbass
 16' Gedeckt, 12 pipes
 8' Principal, 32 notes
 8' Gedeckt, 32 notes
 8' Gemshorn, 32 notes
 4' Gedeckt, 32 notes
 16' Posaune (prepared in solid state)
 8' Trumpet, 32 notes



Levsen Organ Company, Buffalo, IA, has rebuilt the organ at Peoria Christian Reformed Church, Pella, IA. The church had a Berns, Pels, and Zoon organ from Holland, purchased in 1951, which suffered from wood instability in the slider windchests, failure of the pneumatic systems, ciphers and an unstable wind supply. Levsen added two new ranks to the Pels' original 17. Electric action windchests were made, and a new swimmer regulator was built by Levsen. Seven woods were used in the rebuilding, including basswood, walnut, oak, birch, maple, fir and hickory. The dedication was played by Davis Folkerts.

- GREAT**
 8' Open Diapason
 8' Stopped Diapason
 8' Salicional
 4' Octave
 4' Koppelflote
 2' Fifteenth
III-IV Mixture
 8' Trumpet
 Chimes
- SWELL**
 8' Rohrflöte
 8' Salicional
 4' Open Flöte
 2' Octave
II-III Sesquialtera
 8' Trumpet
 Tremolo
- PEDAL**
 16' Bourdon
 16' Lieblich Gedeckt
 10 3/4' Quinte
 8' Octave
 8' Gedeckt
 4' Choralbass
 8' Trumpet

Organ Leathers

Chrome-Tanned & Certified
 Leathers for Organbuilders,
 From Organbuilders

Columbia Organ Leathers

915 Lancaster Avenue
 Columbia, PA 17512
 FAX 717/684-4428

1-800-423-7003
 717/684-2108
(outside continental U.S.)

THE DIAPASON

**An International Monthly
 Devoted to the Organ,
 Harpsichord and
 Church Music**

**Official Journal
 International Society for Organ History and Preservation**

- Feature articles by noted contributors
- Reviews of organ, choral and handbell music, books and recordings
- Stoplists and photos of organ installations
- Monthly calendar of events
- Extensive classified advertising section

THE DIAPASON

380 E. Northwest Highway • Des Plaines, IL 60016-2282

Name

Street

City

State

Zip

Please allow four weeks for delivery of first issue on new subscriptions

- NEW SUBSCRIBER**
 RENEWAL ENCLOSED IS
 \$36.00—3 years
 \$27.00—2 years
 \$18.00—1 year
 Foreign subscriptions:
 \$60.00—3 years
 \$43.00—2 years
 \$28.00—1 year



Mark C. Austin, San Francisco, CA, has rebuilt and installed a 1903 George Kilgen & Son organ at Holy Innocents' Episcopal Church, San Francisco. The organ was originally built for St. Agatha's Conservatory (for Young Women) in St. Paul, MN. After the Conservatory closed, the instrument was reportedly moved to the convent of Sts. Peter & Paul also in St. Paul. St. Benedict's Roman Catholic Church in White Earth, MN, acquired the organ from the convent; it was replaced with an electronic substitute in the 1980s. Holy Innocents' acquired the organ from Alan Laufman of the Organ Clearing House. It was moved to San Francisco in July of 1992. The first phase of the restoration was completed in September, 1992 by Holy Innocents' choirmaster Mark C. Austin, the members of Holy Innocents', and several Bay Area organbuilders. Project advisors are Charles Rus and John deCamp.

GREAT

8' Open Diapason
8' Melodia
4' Principal¹

SWELL

8' Stopped Diapason
4' Harmonic Flute
2' Fifteenth²
8' Oboe³
Tremulant

PEDAL

16' Bourdon

1. Made from cut-down tin Gamba pipes of uncertain origin which most likely predate the Kilgen. CC of the rank is marked "184 Moorehead Gamba" perhaps from an instrument in Moorehead, MN (quite near White Earth). This rank replaces the original 8' Dulciana.

2. Replaces the original 8' Vox Celeste in the Swell.

3. From George S. Hutchings 3/33 (op. 485, 1899) built for the Church of Our Savior (Episcopal) in Brookline, MA, and relocated through the Organ Clearing House.



Petty-Madden Organbuilders has built a new organ, opus 33, for First Baptist Church, Columbia, SC: 35 voices, 53 ranks. The nave of the church seats 3,700 and has over 1.5 million cubic feet of air space. A uniform wind pressure of 5 inches was used for all divisions of the organ. The scaling of the Principal chorus is based on the Pedal 16' Principal which has a diameter of 311 mm (about 12 1/4 inches) and a

mouth width 1/4 of the circumference. Variations of mouth widths, halving ratios, ears, pipe tapers, chimney forms and metal alloy provide tonal variety for the flute stops. All reeds have parallel, open shallots in the 19th-century French style. Stephen Phillips is Minister of Music, Martha Hayes is organist, and Edmund Shay of Columbia College served as consultant.

GREAT

16' Viol Principal
8' Principal
8' Viol Principal
8' Rohr Flute
4' Octave
4' Hohl Flute
2' Octave
V Mixture
8' Trompette
Tremulant

SWELL (enclosed)

8' Viola
8' Viola Celeste
8' Stopped Flute
4' Principal
4' Koppel Flute
2 3/4' Nazard
2' Wald Flute
1 3/4' Tierce
1 1/4' Larigot
VI Mixture
16' Basson
8' Trompette
8' Basson-Hautbois
4' Clairon
Tremulant

POSITIV (enclosed)

16' Bourdon
8' Principal
8' Spitz Flute
8' Spitz Flute
Celeste
8' Gedeckt
4' Octave
4' Spitz Flute
2' Octave
VI Scharf Mixture
8' Trompette
8' Cromorne
Tremulant

PEDAL

32' Resultant
16' Principal
16' Viol Principal (Gt)
16' Subbass
16' Bourdon (Pos)
8' Octave
8' Viol Principal (Gt)
8' Gedeckt Bass
8' Bourdon (Pos)
4' Choral Bass
4' Bourdon (Pos)
V Mixture
16' Bombarde
16' Basson (Sw)
8' Trompette
4' Clairon
4' Hautbois (Sw)

FREE

Pipe Organ Planning & Fund Raising Guide

offered by APOBA, the organization dedicated to expanding and perfecting the art of American pipe organ building. Includes:

- Planning requirements & specifications
- Qualifying & selecting builders
- Educating the congregation
 - Organizing your fund raising committee
- Establishing realistic goals and time tables
- Raising the funds you need.

For your free copy, contact:

Associated Pipe Organ
Builders of America
• P.O. Box 155 •
Chicago Ridge, IL 60415

1-800-473-5270



The Andover Organ Company, Methuen, MA, has completed its Opus 103 for Gordon-Conwell Theological Seminary, South Hamilton, MA. The organ was given in memory of Joseph M. Cunningham by his son, Joseph M. Cunningham, Jr. The two-manual and pedal organ was designed to complement the contemporary chapel at the Seminary. The original design made no provision for a pipe organ, so a portion of the three-sided balcony was removed and the free standing instrument was installed to the left of the altar area.

The case is built of solid maple to complement the birch and brick chapel. The facade pipes are of 80% polished tin with round shades of polished copper. The console is of solid cherry with rosewood turned knobs and bone labels. The keyboards have bone naturals and ebony sharps. The key and stop actions are mechanical and the couplers are on hitch-down pedals. The Pedal includes a mechanical unit stop of 16', 8' and 4' pitches. This stop features a stopped wood bass and changes to tapered open metal pipes in the treble. With variable voicing and scaling, the sound ranges from a flute in the bass to a principal quality in the 4' range.

The case was designed by Donald H. Olson, the mechanical design was by Benjamin Mague and the tonal design and finishing was by Robert J. Reich. The organ was dedicated by Brian Jones, organist of Trinity Church, Copley Square, Boston, playing works by Bach, Buxtehude, Lefébure-Wély, Franck and Hollins.

GREAT

8' Principal
8' Gemshorn
4' Octave
2' Mixture IV
8' Trumpet

SWELL

8' Gedeckt
4' Chimney Flute
2' Recorder
Cornet II
8' Oboe

PEDAL

16' Subbass
8' Flutebass (12 pipes)
4' Choralbass (12 pipes)
16' Trombone

Calendar

This calendar runs from the 15th of the month of issue through the following month. **The deadline is the first of the preceding month** (Jan 1 for Feb issue). All events are assumed to be organ recitals unless otherwise indicated and are grouped within each date north-south and east-west. * = AGO chapter event, ** = RCCO centre event, + = new organ dedication, ++ = OHS event. Information cannot be accepted unless it specifies **artist name, date, location, and hour** in writing. Multiple listings should be in chronological order, please do not send duplicate listings. THE DIAPASON regrets that it cannot assume responsibility for the accuracy of calendar entries.

UNITED STATES East of the Mississippi

17 JULY
Ronald Cross, harpsichord; Donnell Library Auditorium, New York, NY 2:30 pm
Brian Swager, carillon; Culver Academy, Culver, IN 4 pm

18 JULY
Jeffrey Smith; National Shrine, Washington, DC 6 pm
Robert Parkins; Univ of Notre Dame, South Bend, IN 8 pm
OHS Convention; Louisville, KY (through July 24)

19 JULY
Harpsichord Workshop; Westminster Choir College, Princeton, NJ (through July 23)

20 JULY
Susan Armstrong; Madison Historical Society, Madison, IN 10:45, 11:45 am

21 JULY
Janice Beck; Mem Music Hall, Methuen, MA 8 pm
Karel Paukert, clavichord; Cleveland Museum, Cleveland, OH 7:15 pm
+ **Boyd Jones**; St Andrew's Episcopal, Louisville, KY 8 pm

25 JULY
Berj Zamkochian; National Cathedral, Washington, DC 4:45 pm
Cyprian Constantine, OSB; National Shrine, Washington, DC 6 pm
Sally Cherrington; Cathedral of the Holy Angels, Gary, IN 3 pm

27 JULY
Marilyn Keiser; The Riverside Church, New York, NY 7 pm

28 JULY
Roland Münch; Mem Music Hall, Methuen, MA 8 pm
John Walker; St Stephen's, Richmond, VA 8 pm

1 AUGUST
Karl Moyer, with ensemble; First Congregational, Orwell, VT 7:30 pm
Kim Heindel, harpsichord; Moravian College, Bethlehem, PA 7:30 pm
Richard Stockdale; National Shrine, Washington, DC 6 pm

4 AUGUST
Massimo Nosetti; Mem Music Hall, Methuen, MA 8 pm
Jacques Taddel; Cleveland Museum, Cleveland, OH 8 pm

5 AUGUST
Todd Wilson; National Music Camp, Interlochen, MI 8 pm

6 AUGUST
Todd Wilson, seminar; National Music Camp, Interlochen, MI

8 AUGUST
Phillip Compton; National Shrine, Washington, DC 6 pm

10 AUGUST
Harold Stover; First Parish Church, Brunswick, ME 12:10 pm
David Craighead; Community of Jesus, Orleans, MA 8 pm

11 AUGUST
David Craighead, masterclass; Community of Jesus, Orleans, MA (through August 16)
Robert Sutherland Lord; Mem Music Hall, Methuen, MA 8 pm

15 AUGUST
Fauré, Requiem; Community of Jesus, Orleans, MA 5 pm
Carlene Neihart; National Cathedral, Washington, DC 4:45 pm
Mary Beth Bennett; National Shrine, Washington, DC 6 pm
Martin Jean; The Baptist Temple, Charleston, WV

17 AUGUST
Harold Stover; City Hall Auditorium, Portland, ME 7:30 pm

18 AUGUST
Joseph Butler; Mem Music Hall, Methuen, MA 8 pm

19 AUGUST
Kim Heindel; Central Moravian Church, Bethlehem, PA 5 pm

22 AUGUST
Boyd Jones; National Shrine, Washington, DC 6 pm

25 AUGUST
Harold Stover; Cathedral of the Immaculate Conception, Portland, ME 12:15 pm
Linton Powell; Mem Music Hall, Methuen, MA 8 pm

29 AUGUST
Ronald Stolk; National Shrine, Washington, DC 6 pm

UNITED STATES West of the Mississippi

20 JULY
Robert Scoggin, with cello; Christ United Methodist, Rochester, MN 12:20 pm
Conference on Music; St Olaf College, Northfield, MN (through July 23)

21 JULY
Nora Christiansen; First United Methodist, Sioux Falls, SD 12:15 pm

23 JULY
Mikael Wahlin; Crystal Cathedral, Garden Grove, CA 8:15 pm

25 JULY
Mary Preston; St John's Cathedral, Denver, CO 8 pm
Choral Concert; Immanuel Presbyterian, Los Angeles, CA 4 pm

27 JULY
Ruth Benning; Christ United Methodist, Rochester, MN 12:20 pm

28 JULY
David Moklebust; First United Methodist, Sioux Falls, SD 12:15 pm

30 JULY
Marian & David Craighead; St John's Cathedral, Denver, CO 8 pm

3 AUGUST
Jeffrey Daehn; Christ United Methodist, Rochester, MN 12:20 pm

4 AUGUST
Eugene Douth; First United Methodist, Sioux Falls, SD 12:15 pm

11 AUGUST
Marcia Kittelson; First United Methodist, Sioux Falls, SD 12:15 pm

13 AUGUST
Massimo Nosetti; Crystal Cathedral, Garden Grove, CA 8:15 pm

robert anderson

SMD FAGO

Southern Methodist University
Dallas, Texas 75275

CHARLOTTE AND WILLIAM

ATKINSON

FIRST PRESBYTERIAN CHURCH
2001 El Camino Real
Oceanside, California 92054

WILLIAM AYLESWORTH

D. M.

Evanston, Illinois

ROBERT CLARK

School of Music

ARIZONA STATE UNIVERSITY
TEMPE, ARIZONA 85281

WALLACE M. COURSEN JR.

F.A.G.O.

Holy Trinity Episcopal Church
West Orange, NJ 07052

GEORGE W. DECKER

St. Paul's Cathedral
Syracuse, NY 13202

STEVEN EGLER

Central Michigan University
First Presbyterian Church
Mt. Pleasant, Michigan 48858

SOLO Shelly-Egler
RECITALS Flute and Organ Duo

JOHN FENSTERMAKER

GRACE CATHEDRAL
SAN FRANCISCO

ELLEN KURTZ

FUNK

M. Mus. A.A.G.O.
Concord, California

CHRISTOPHER GARVEN

Organist/Conservatory Director
Ormond Beach First Baptist, FLA
recitals, call: (904)672-1822

John M. Gearhart III
B.A., M. Mus.

St. Paul's Episcopal Church
P.O. Box 8427
Mobile, Alabama 36608

Robert Glasgow

School of Music
University of Michigan
Ann Arbor

Antone Godding

School of Music

Bishop W. Angie Smith Chapel
Oklahoma City University

BRUCE GUSTAFSON

Franklin and Marshall College
Lancaster, Pennsylvania

Instruction - Talks - Consulting

CARILLON

Margo Halsted
University of Michigan School of Music
Ann Arbor, MI 48109

WILL HEADLEE

1650 James Street
Syracuse, NY 13203-2816
(315) 471-8451

Gruenstein Award Sponsor

CHICAGO
CLUB OF
WOMEN
ORGANISTS

Dolores B. Soderberg, President

Founded 1928

A two-inch Professional Card in THE DIAPASON

Call for rates
Phone 708/298-6622
Fax 708/390-0408

DAVID BURTON BROWN

Director of Music
ST. JAMES EPISCOPAL CHURCH
Birmingham, Michigan



ORGAN RECITALS

Contact:
Aurand
Management
19651 Hickory Leaf
Southfield, MI 48076
(313) 424-9217

SYLVIE POIRIER

PHILIP CROZIER

ORGAN DUO

4702 Queen Mary Road, Apt 10
Montreal, H3W 1W8, P. Quebec
Canada
(514) 739-8696

VICTOR HILL

Harpichord and Organ
Williams College
St. John's Episcopal Church
Williamstown, Mass. 01267

Your Professional Card
could appear in this space

Call 708/298-6622
Fax 708/390-0408

Brian Jones

TRINITY CHURCH
BOSTON

JAMES KIBBIE

D.M.A.
The University of Michigan
School of Music
Ann Arbor, MI 48109

WILLIAM KUHLMAN

Decorah, Iowa 52101
Luther College

David Lowry

School of Visual and
Performing Arts
Winthrop University
Rock Hill, SC 29733

DAVID McCAIN

ORLANDO

WILLIAM H. MURRAY

Mus. M.F.A.G.O.
St. John's Episcopal Church
215 North Sixth Street
Dort Smith, Arkansas 79201

A two-inch Professional Card
in

THE DIAPASON

Please write for rates
380 E. Northwest Highway
Des Plaines, IL 60016-2282

708/298-6622

Fax 708/390-0408

MARILYN MASON

CHAIRMAN, DEPARTMENT OF ORGAN
UNIVERSITY OF MICHIGAN
ANN ARBOR

"... Ginastera's ... was by all odds the most exciting ... and Marilyn Mason played it
with awesome technique and a thrilling command of its daring writing."

The American Organist, 1980

MICHAEL GAILIT

Organist—Pianist



HOCHSCHULE FÜR MUSIK
Lothringerstrasse 18
A-1030 VIENNA, AUSTRIA

Harry H. Huber

D. Mus.
Kansas Wesleyan University, Emeritus
University Methodist Church
SALINA, KANSAS

MICHELE JOHNS

A.Mus.D
Organ — Harpsichord
The University of Michigan
School of Music

KIM R. KASLING

D.M.A.
St. John's University
Collegeville, MN 56321

GALE KRAMER

DMA
Wayne State University
Metropolitan Methodist Church
Detroit 48202

Richard Litterst

M.S.M.
First Presbyterian Church
Freeport, Illinois

BETTY LOUISE LUMBY

DSM • FAGO
UNIVERSITY OF MONTEVALLO
MONTEVALLO, ALA. 35115



Sue Mitchell-Wallace

A.S.C.A.P.
FELLOW, AMERICAN GUILD OF ORGANISTS

345 SADDLE LAKE DRIVE
ROSWELL-ATLANTA, GEORGIA 30076
(404) 594-0948

LEON NELSON

THE MOODY CHURCH
CHICAGO, IL 60614
FIRST PRESBYTERIAN CHURCH
DEERFIELD, IL 60015

DAVID GOODING

St. Peter's Episcopal Church

18001 Detroit Avenue
Lakewood, OH 44107

16 AUGUST

Massimo Nosetti; Balboa Park, San Diego,
CA 8 pm

20 AUGUST

Massimo Nosetti; First Lutheran, Alexandria,
MN 7:30 pm

29 AUGUST

Martin Jean, hymn festival; Meyerson Sym-
phony Hall, Dallas, TX

INTERNATIONAL

15 JULY

Simon Preston; Ripon Cathedral, England
7:30 pm

David Burton Brown; Kirche Alt-Tegel, Berlin,
Germany 8 pm

16 JULY

George Ritchie, Gisele Guibord, with instru-
ments; St James United Church, Montréal, Qué-
bec, Canada 8 pm

17 JULY

Hans Fagius; Grosvenor Chapel, London,
England 7:30 pm

Timothy Hone; Clifton Cathedral, England
7:30 pm

David Burton Brown; Marktkirche, Wiesba-
den, Germany noon

David Burton Brown; Stiftskirche, Bad Hers-
feld, Germany 4 pm (also July 18, 4 pm)

19 JULY

IAO Organ Festival; Cambridge, England
(through July 24)

20 JULY

Carleton Etherington; St Mary Redcliffe, Bris-
tol, England 7:30 pm

21 JULY

Verleen Baerg; Holy Rosary Cathedral, Re-
gina, Saskatchewan, Canada 8 pm

24 JULY

David Burton Brown; St Nikolai, Kiel, Ger-
many 4 pm

Marek Kudlicki; Stiftskirche, Melk, Austria 6
pm

25 JULY

Ian Moore & Anne Page; St Catharine's Col-
lege Chapel, Cambridge, England 4 pm

27 JULY

Lahti Organ Festival; Lahti, Finland (through
August 3)

30 JULY

Louis Thiry; King's College Chapel, Cam-
bridge, England 7:30 pm

1 AUGUST

International Summer Organ Academy; St An-
toine L'Abbaye, France (through August 12)

Thomas Schlee; King's College Chapel, Cam-
bridge, England 6 pm

3 AUGUST

John Marsh; St Mary Redcliffe, Bristol, Eng-
land 7:30 pm

Jeff Reusing; St James United Church, Mon-
tréal, Québec, Canada 12:30 pm

4 AUGUST

Roert Parkins; Parish Church, Haringe,
Belgium

Maxine Thevenot; Holy Rosary Cathedral,
Regina, Saskatchewan, Canada 8 pm

6 AUGUST

Lionel Rogg; Trinity College Chapel, Cam-
bridge, England 7:30 pm

8 AUGUST

Herman Verschraegen; St Catharine's Col-
lege Chapel, Cambridge, England 4 pm

9 AUGUST

Francis Jackson; Lincoln Cathedral, England
7 pm

10 AUGUST

Nina de Sole; St James United Church, Mon-
tréal, Québec, Canada 12:30 pm

11 AUGUST

Robert Parkins; Grote Kerk, Leeuwarden,
Netherlands

13 AUGUST

Cherry Rhodes; Augustiner-Kirche, Vienna,
Austria 7:30 pm

15 AUGUST

Robert Parkins; St Lars Church, Linköping,
Sweden

17 AUGUST

Roy Massey; St Mary Redcliffe, Bristol, Eng-
land 7:30 pm

18 AUGUST

Robert Parkins; Haga Church, Gothenburg,
Sweden

Jeffrey Jones; Holy Rosary Cathedral, Re-
gina, Saskatchewan, Canada 8 pm

21 AUGUST

Robert Parkins; Caroli Church, Borås,
Sweden

Francis Jackson; Grosvenor Chapel, London,
England 7:30 pm

24 AUGUST

Robert Parkins; Cathedral, Brussels, Belgium

Tom Harris; St James United Church, Mon-
tréal, Québec, Canada 12:30 pm

29 AUGUST

Marek Kudlicki; Cathedral, Rzeszów, Poland
8 pm

Steve Gentile; Cathédrale St-Etienne,
Auxerre, France 5 pm

30 AUGUST

Barry Rose; Liverpool Cathedral, England
11:15 am

Colin Walsh; Lincoln Cathedral, England 7
pm

31 AUGUST

Paul Derrett; St Mary Redcliffe, Bristol, Eng-
land 7:30 pm

Mark McClellan; St James United Church,
Montréal, Québec, Canada 12:30 pm

Organ Recitals

WILLIAM ALBRIGHT, Wesleyan Uni-
versity, Middletown, CT, February 4: *Pas-
toral Drone*, Crumb; *Episode*, Copland;
Chant d'oiseaux, Messiaen; *Dream, Souve-
nir*, Cage; *Hydraulis*, Bolcom; *Four Fancies
for Harpsichord*, Albright; *Do, do, do*,
Gershwin; *Lotus*, Strayhorn; *Saint Louis
Blues*, Handy/Waller; *King of Instruments*,
Albright.

SUSAN ARMSTRONG, Yale University,
New Haven, CT, March 21: *Trumpet Tune*,
Hannahs; *Etude Symphonique*, op. 78, Bossi;
Lied to the Sun, op. 66, no. 5, Peeters;
Variations de Concert, op. 1, Bonnet; *Flight
of the Bumblebee*, Rimsky-Korsakov/Ellsas-
ser; *Bach's Memento*, Widor; *Final (Sympho-
nie No. 6)*, Vienne.

GORDON ATKINSON, with Thiel Col-
lege Handbell Ringers, Thiel College,
Greenville, PA, March 16: *Praeludium in C*,
BuxWV 137, Buxtehude; *Praeludium in E*,
Bruhns; *Pieces for a Musical Clock*, Handel;
Voluntary in C, Greene; Introduction and
Passacaglia (*Sonata No. 8*), Rheinberger; *So-
nata No. 2*, Hindemith; *Lord of Glory who
has brought us, Open now thy gates of
beauty*, Manz; *Soliloquy*, Variations on "Lead
on, O King Eternal," Atkinson.

LOUISE BASS, St. John's Cathedral, Al-
buquerque, NM, March 30: *Sonata in E-
flat*, KV 67, *Sonata in F*, KV 244, Mozart;
Adagio (Symphony III), Westminster Caril-
lon, Vienne.

BRENDA LYNNE LEACH

Doctor of Musical Arts
Premier Prix de Virtuosité

Harvard
University
Adjunct
Faculty



Clark
University
Adjunct
Faculty

Director of Music & Creative Arts
Church of the Covenant
67 Newbury Street
Boston, MA 02116

H 617/723-5087 W 617/266-7480

ASCAP

ORGANIST-CHOIRMASTER
THE PILGRIM UNITED CHURCH
OF CHRIST
130 BROAD BLVD.
CUYAHOGA FALLS, OHIO 44221

JAMES BIERY, Cathedral of St. Joseph, Hartford, CT, March 28: *Le Chemin de la Croix*, op. 29, Dupré.

BYRON L. BLACKMORE, with La Crosse Trombone Ensemble and Paul Rusterholz, bass, St. Rose Convent, La Crosse, WI, February 28: *Prelude and Fugue in E Minor*, op. 37, no. 4, Hesse; *Flourish*, Held; *Partita on "O Gott, du frommer Gott,"* S. 767, Bach; *A Swan*, Hindemith; *Improvisation*, op. 150, no. 7, Saint-Saëns; *Preludes on Welsh Hymn Tunes: Bryn Calvaria, Rhosymedre*, Vaughan Williams; *Fili me, Absalon*, SWV 269, Schütz; *Sonata for Four Trombones and Basso Continuo*, Speer; *At Compline (The Book of Hours)*, Pinkham; *Improvisation on "Te Deum Laudamus,"* Tournemire.

JEROME BUTERA, Park Ridge Community Church, Park Ridge, IL, March 17: *Sketch in F Minor*, Schumann; *Choral No. 2 in B Minor*, Franck; *Fugue on the name ALAIN*, Duruflé.

LAWRENCE CAVE, St. John's Cathedral, Albuquerque, NM, March 9: *Répons pour le temps de Pâque*, Demessieux; *Prelude, Fugue and Variation*, Franck; *Fantasia in G*, S. 572, Bach.

STEPHEN CLEOBURY, Busch-Reisinger Museum, Cambridge, MA, March 21: *Nun danket alle Gott*, op. 65, Karg-Elert; *Prelude and Fugue in B Minor*, S. 544, Bach; *Bergamasca*, Frescobaldi; *Trio Sonata in E-flat*, S. 525, Bach; *Cantilena Anglica Fortunae*, Scheidt; *Chorale Preludes from Clavierübung III*, Bach; *Fantasia in Echo*, Sweelinck; *Prelude and Fugue in C Minor*, op. 37, no. 1, Mendelssohn.

MARIAN & DAVID CRAIGHEAD, St. Mark's Cathedral, Seattle, WA, January 15: *Choral and Alleluia*, Hanson; *Variations on an Original Theme for Organ Duet*, op. 55, Cabena; *Concerto No. 6 in D Major*, Soler; *Dialogues on a Scottish Psalm-tune for Organ Duet*, op. 73, Leighton; *Sonata in D Minor*, op. 30, Merkel; *Intermezzo, Fugue (Pieces for Two Players)*, Brown; *Bombardo-Carillon*, Alkan.

CATHARINE CROZIER, St. Paul's United Church of Christ, Chicago, IL, March 28: *Choral in B Minor*, Franck; *Veni Creator*, de Grigny; *Three Dances*, Alain; *Ave Maria, Ave Maris Stella, Hymne d'Actions de Grâce, Te Deum*, Langlais.

PHILIP CROZIER & SYLVIE POIRIER, St. John's Church, Canberra, February 12: *Duet for Organ*, Wesley; *Prelude and Fugue in B-flat*, Albrechtsberger; *Fugue in E Minor*, op. posth. 152, Schubert; *Introduction and*

Fugue in D Minor, Lachner; *Sonata in D Minor*, op. 30, Merkel; *A Fancy for Two to Play*, Tomkins; *A Verse*, Carleton; *Toccata Français sur le nom de HELMUT*, Böllting.

BRIAN Wm. DAVEY, Music at the Palms, Delray Beach, FL, March 7: *Carillon*, Vierne; *Air for the G String, Prelude and Fugue in D Major*, Bach; *Berceuse*, Dupré; *Scherzo (Symphonie II)*, Vierne; *Tu es Petra*, Mulet; *Toccatina*, Atkinson; *Romanza*, op. 45, Grieg; *Toccata in B Minor*, Gigout; *Liebestod*, Wagner; *Finale (Symphonie VI)*, Widor.

DAVID DiFIORE, First Presbyterian Church, Everett, WA, March 7: *Prelude and Fugue in A minor, Blessed Jesus, we are here, Toccata and Fugue in D Minor*, Bach; *A Suite of Dances*, Phalese; *Final (Symphony No. 6)*, Vierne; *Pièce Héroïque*, Franck; *Variations on "America,"* Ives; *Etude Symphonique*, Bossi.

MATTHEW DIRST, harpsichord and organ, Cleveland Museum of Art, Cleveland, OH, March 21: *Partita IV in D Major*, S. 828, J.S. Bach; *Fugues in C Minor, D Major and D Minor*, W.F. Bach; *Sonata in A Minor*, Wq. 70/4, C.F.E. Bach; *Prelude, Trio and Fugue in G Major*, S. 541/528, J.S. Bach.

DELBERT DISSELHORST, Cathedral of St. John the Evangelist, Spokane, WA, March 21: *Sonata III*, op. 65, Mendelssohn; *Lord Jesus Christ unto us turn*, S. 555, *All glory be to God on high*, S. 562, *Toccata and Fugue in F Major*, S. 540, Bach; *Prelude in E-flat*, Lemmens; *Impromptu*, Vierne; *There is a happy land, Amazing grace*, Shearing; *Prelude and Fugue in B Major*, op. 7, Dupré.

JOHN EGGERT, Lutheran Church of the Redeemer, St. Paul, MN, January 24: *Præ-ludium in G Minor*, Buxtehude; *A German Dance*, Tablature of Johannes of Lublin; *Partita on "Wachet auf,"* Distler; *Noël IV*, Daquin; *Variations on Wondrous Love*, Eggert; *Ballade en mode Phrygien*, Alain; *Prelude and Fugue in E-flat*, Bach.

MARY FENWICK, Daylesford Abbey, Paoli, PA, February 21: *Lobe den Herren*, Walcha, Bach; *Qui tollis peccata mundi* (Parish Mass), Couperin; *Giga*, Bossi; *Fantasy and Fugue in G Minor*, S. 542, Bach; *Salve Regina*, Falcone; *Suite*, op. 5, Duruflé.

JAMES W. GOOD, Northminster Church, Monroe, LA, March 21: *Petite Suite*, Bales; *Schmücke dich*, Homilius; *Concerto II in g*, Camidge; *Liebster Jesu*, S. 731, *Nun freut euch*, S. 734, *Toccata in F*, S. 540, Bach; *Prelude and Fugue in E-flat*, op. 99/III, Saint-Saëns; *Herzlich thut mich verlan-*

DUDLEY OAKES

D.M.A.

Thiel College
75 College Avenue
Music Department
Greenville, PA 16125

KATHARINE PARDEE

HENDRICKS CHAPEL
SYRACUSE UNIVERSITY

RICHARD M. PEEK

Sac. Mus. Doc.

Covenant Presbyterian Church
1000 E. Morehead Charlotte, N. C.

DOUGLAS REED

UNIVERSITY OF EVANSVILLE
EVANSVILLE, INDIANA

STEPHEN G. SCHAEFFER

D.M.A.

The Cathedral Church
of the Advent
Birmingham, Alabama 35203

James Gillis Saenger

Washington ★ DC
Cathedral Carillonneur

Dennis Schmidt

DMA

Executive Director
The Bach Festival
of Philadelphia

LARRY SCHOU

D.M.A.

The University of
South Dakota
Music Department
Vermillion, SD 57069-2390

Robert Shepfer

Organist - Choirmaster
SECOND PRESBYTERIAN CHURCH

Indianapolis, Indiana 46260

Recitals

ROBERT L. SIMPSON

Cathedral of St. Philip
2744 Peachtree Road N.W.
Atlanta, Georgia 30305

David Wagner

DMA

St. Paul Church
Grosse Pointe Farms, Michigan 48236
WQRS-FM Detroit

BEAL THOMAS

Church of the Ascension
and St. Agnes
Washington, DC

SALLY SLADE WARNER, AAGO, ChM

Carillonneur

St. Stephen's Church, Cohasset, MA
Phillips Academy, Andover, MA

Recitals

KARL WATSON

TRINITY LUTHERAN CHURCH
STATEN ISLAND

DONALD W. WILLIAMS

D.M.A.

Zion Lutheran Church
Concordia College
Ann Arbor, MI

RONALD WYATT

Trinity Church

Galveston

A radio program for the king of instruments

- JULY
- #9327 Summer Sketches . . . portraits of historic instruments in Portland and Bangor (Maine), Ocean Grove (New Jersey) and Round Lake (New York), organs famous for their summer concert schedules.
 - #9328 The Great Organ at Methuen . . . Roberta Bitgood, John Skelton, Dana Robinson, James Welch and others play this legendary instrument in its magnificent, purpose-built hall in upstate Massachusetts.
 - #9329 Organ Plus . . . music by Bach, Dupré, Malcolm Boyle, Monte Mason, Elliott Schwartz and others features the organ with brasses, choirs and synthesizers.
 - #9330 Lahti Festival Report . . . recital selections by Janna Ikonen, Kevin Bowyer, Guy Bovet, Gunnar Idenstam and Markus Wargh from the summer series at Church of the Cross in Lahti, Finland.



PIPEDREAMS is a weekly radio series produced by Minnesota Public Radio and broadcast over stations of the American Public Radio network. For more information, contact your local public radio station, or call APR at 612-338-5000.

LARRY PALMER

Professor of

Harpichord and Organ

Meadows School of the Arts

SOUTHERN METHODIST UNIVERSITY

Dallas, Texas

75275

Musical Heritage Society recordings

LAWRENCE

ROBINSON

VIRGINIA COMMONWEALTH UNIVERSITY

RICHMOND, VIRGINIA

DAVID SPICER

First Church of Christ
Wethersfield, Connecticut



House Organist
The Bushnell Memorial
Hartford

GORDON YOUNG



Mus. Doc., A.S.C.A.P.

ORGAN BUILDERS.

**SIMPLIFY
YOUR ORGAN
INSTALLATIONS**

**MULTI-ACTION
ORGAN CONTROL**



THE STANDARD OF THE INDUSTRY

If you are rebuilding a large pipe organ and have a deadline to meet, simplify the task by using the Devtronix **MULTI-ACTION** Computer Control Unit

WHAT OTHER SYSTEM CAN—

FUNCTION AS A

- RELAY
- COMBINATION ACTION
- RECORD & PLAYBACK

IN ONE SMALL PACKAGE WITH VERY LITTLE HARDWARE OR WIRING?

WHAT OTHER SYSTEM CAN—MAKE SPECIFICATION CHANGES IN SECONDS WITHOUT TOUCHING A SOLDERING IRON?

WHAT OTHER SYSTEM CAN—REQUIRE NO MAINTENANCE BECAUSE OF ITS HIGH RELIABILITY?

WHAT OTHER SYSTEM CAN—BE USER FRIENDLY?

EXCELLENT WIRING AND OPERATING MANUALS

Save time and trouble with this remarkable system—write today for free brochure



1823 AVONDALE AVE.
SACRAMENTO, CA 95825
(916) 971-9074

**KOPPEJAN
Pipe Organs Inc.**

48228 Yale Rd. E., Chilliwack, B.C.
Canada, V2P 6H4

(604) 792-1623

NOACK

THE NOACK ORGAN CO. INC.
MAIN AND SCHOOL STREETS
GEORGETOWN, MASS. 01833
TELEPHONE: (508) 352-6266



**A & J Reed &
Pipe Organ Service**

ARCHIE MARCHI & JOE CORKEDEALE

(914) 561-1480

36 CARTER STREET NEWBURGH, NY 12550

**AUSTIN
ORGANS**

ORGAN ARCHITECTS AND BUILDERS

156 WOODLAND STREET HARTFORD, CT 06105

(203) 522-8293

FOR SALE

This space, as low as \$30 per issue on a 12-insertion contract. Want more details? Rate card sent on request.

THE DIAPASON
380 Northwest Highway
Des Plaines, IL 60016

M. L. BIGELOW & Co.
ORGAN BUILDERS
(801) 756-5777
130 W. 1st S., American Fork, UT 84003

ORGAN BUILDERS
L. W. BLACKINTON
and associates, inc.
380 FRONT ST
EL CAJON, CA 92020

Geddes Pipe Organs
Tuning and Maintenance
*Custom Voicing *Rebuilding *Restorations
*New Instruments
P.O. Box 18343 Austin, Texas 78760
512-385-2710

Repair and Service Tuning and Additions
Milliman Organ Co.
ROBERT L. MILLIMAN
3300 Patricia Dr.
1-515-270-6913 Des Moines, Iowa 50322

3165 Hill Road
Eagleville, TN 37060
(615) 274-6400
CUSTOM BUILDING
&
RESTORATIONS

PIPE ORGAN BUILDERS
4820 BRISTOL VALLEY ROAD
CANANDAIGUA, NY 14424-9309
716-229-5888

**QUIMBY PIPE ORGANS
INCORPORATED**
WARRENSBURG, MISSOURI
P. O. Box 434 Warrensburg, MO 64093
816/747-3066

Reisner
...Since 1897
P.O. Box 71 / Hagerstown, MD USA 21741

**ROCHE
Organ Co., Inc.**
799 West Water Street
Taunton, Mass 02780
pipe organs

B. RULE & COMPANY
Designing & Building
Tracker Pipe Organs of Singular Merit
P.O. Box 64 • New Market, TN 37820
615-475-9125

PIPE ORGAN BUILDERS - EST. 1877
SCHOENSTEIN
SAN FRANCISCO
3101 20th ST., 94110 • (415) 647-5132

**John-Paul
Buzard** Organ Craftsmen, Inc.
112 W. Hill St. ♦ Champaign, IL 61820 ♦ 217.352.1955

gen, Brahms; *Fugue on BACH*, op. 60/1, Schumann; *Partita, St. Anne*, op. 6, Manz.

SUSAN GOODSON, Algoma Boulevard United Methodist Church, Oshkosh, WI, March 10: *My heart is ever yearning*, op. 122, no. 9, Brahms; *Scherzetto*, Vierne; *Elevation*, op. 32, no. 1, Dupré; *Choral Poems on the Seven Last Words of Christ*, op. 67: II. "Today you shall be with me in paradise," Tournemire; *O sacred head now wounded, Prelude and Fugue in E Minor*, S. 533, Bach.

WILLIAM D. GUDGER, First (Scots) Presbyterian Church, Charleston, SC, March 28: *Voluntary in G Major*, op. 1, no. 5, Walond; *Voluntary in D Minor*, Wesley; *Voluntary II in F Major*, Russell; *Cloister-Garth (alla Sarabanda)*, Brewer; *Elegy (for Walford Davies)*, Thalben-Ball; *Chorale Prelude on "St. Ann's"*, Parry; *Cantabile*, Franck; *Cortège et Litanie*, op. 19, Dupré; *Adagio, Finale (Symphonie VI)*, Widor.

SHARON BANKS HAIGLER, Southeastern Baptist Theological Seminary, Wake Forest, NC, March 27: *Processional*, Mathias; *Ich ruf zu dir*, S. 639, Wer nur den lieben Gott lässt walten, S. 642, Bach; *Präludium und Fuga in D Major*, BuxWV 139, Buxtehude; *The Lord's Prayer*, Camilieri (with Joe Haigler, baritone); *Benedictus*, op. 59/9, Reger; *I Mode de ré, VIII Mode de sol*, Langlais.

JUDITH HANCOCK, Christ Church Cathedral, St. Louis, MO, February 23: *Prelude and Fugue in A Minor*, BuxWV 153, Buxtehude; *Liebster Jesu*, S. 730, 731, *Concerto in A Minor*, S. 593, Bach; *Prelude and Fugue in E-flat, Saint-Saëns; Preludes and Fugues*, op. 7, nos. 1-3, Dupré; *Passacaglia quasi Toccata on BACH*, Sokola.

DAVID HIGGS, Northwestern University, Evanston, IL, March 5: *Toccata Prima*, Muffat; *Mein junges Leben hat ein End*, Sweelinck; *Sonata No. 5 in C Major*, S. 529, Bach; *Sonata No. 1 in F Minor*, op. 65, Mendelssohn; *Pastorale and Toccata*, Conte; *Fantasmagorie, Deux Danses à Agni Yavshita*, Alain; *Primitives, At the Ballet, Evelyne Dance (Five Dances)*, Hampton.

ANN LABOUNSKY, St. Paul's on the Green, Norwalk, CT, March 7: *Carillon de Westminster*, Vierne; *Scherzo*, Duruflé; *Prière*, Franck; *Fête*, Langlais; *Grand Pièce Symphonique*, Franck; Improvisation on submitted themes.

DANIEL LAMOUREUX, with Margaret Angelini, organist, and Chet Raymo, narrator, Stonehill College, March 23: *Festal March*, Kroeger; *Andante (Sonata No. 4)*, Guilman; *Tambourin provençal*, Moraçon; *Sonata in A*, op. 18, no. 5, J.C. Bach; *Biblical Sonata No. 1*, Kuhnau; *Barcarolle (Tales of Hoffman)*, Offenbach/Lemare; *Swanee River*, Foster/Lemare; *Fantasia*, K. 594, Mozart; *A Fancy for two to play*, Tomkins; *Homage to Jean Gallon*, Duruflé; *Fantaisie (Homage to Frescobaldi)*, Langlais.

HAENG JOON LEE, Southeastern Baptist Theological Seminary, Wake Forest, NC, March 29: *Partita, "Praise, my soul, the King of heaven"*, Hobby; *Concerto III del Sigr. Meck*, Walther; *Nun komm, der Heiden Heiland*, S. 659, Praeludium et Fuga in d, S. 549a, Bach; *Apparition de l'Eglise éternelle*, Messiaen; *Come, thou fount of every blessing*, Manz; *Toccata on "Rejoice, ye pure in heart"*, Travis.

MARY MOZELLE, Washington National Cathedral, Washington, DC, March 21: *Toccata, Adagio and Fugue in C Major*, S. 564, Bach; *Prelude on "Were you there?"* Sowerby; *Allegro (Symphony No. 6)*, Widor; *Sonata on the 94th Psalm*, Reubke.

KAREL PAUKERT, organ and harpsichord, Museum of Art, Cleveland, OH, January 10: *Toccata quinta*, Frescobaldi; *Toccata prima*, Muffat; *Canzon octavi toni*, Erbach; *Passacaglia*, Kerll; *Sonata in A Major*, Galuppi; *Sonata in F Major*; Pergolesi; *Concerto in F*, Hasse; *Sonata in G Major*, Bellini.

RICHARD M. PEEK, St. Michael's Lutheran Church, Greenville, SC, February 21: *Prelude and Fugue in F-sharp Minor*, Buxtehude; *Kommst du nun, Jesu, vom Himmel herunter*, *Prelude and Fugue in C Major*, S. 547, Bach; *Flötenuhr*, Haydn; *Prelude, Fugue et Variation*, Franck; *Prelude on "St. Michael's"*, Peek; *Partita on "Ein feste Burg"*, Kee; *Grand Choeur Dialogue*, Gigout.

CHRISTA RAKICH, First Presbyterian Church, Dallas, TX, March 8: *Batalla de sexto tono*, Ximénez; *Toccata in E*, Bach; *Vater unser im Himmelreich*, Böhm; *Passacaglia in C-sharp minor*, Borroff; *Allegro (Symphony No. 6)*, Widor; *Prelude and Fugue on "O Traurigkeit"*, Smyth; *O filii et filiae, Domine Jesu, Veni creator*, Demessieux; *Lobe den Herren, Herr Jesu Christ, Aus tiefer Not, Nun jauchzt dem Herren, Morgenglanz der Ewigkeit, Vater unser im Himmelreich*, Wieruszowski; *Lotus*, Strayhorn; *Allegro maestoso e vivace (Sonata No. 4)*, Mendelssohn.

LINDA RANEY, St. John's Cathedral, Albuquerque, NM, March 16: *Toccata and Fugue in D Minor*, S. 538, Bach; *Pièce Héroïque*, Franck; *Allegro vivace (Symphony I)*, Carillon (24 Pieces), Vierne.

EDMUND SHAY, St. James Lutheran Church, Red Bank, SC, April 25: *Finale (Symphony No. 2)*, Widor; *Prelude, Fugue and Variation*, Franck; *Prelude and Fugue in C Major*, Boehm; *Echo ad manuale duplex*, Scheidt; *Vater unser im Himmelreich*, S. 636, Bach; *Sonata VI*, first movement, Mendelssohn; *Voluntary in D Major*, Boyce; *Prelude and Fugue in C Major*, S. 547, Bach; *Variations on "Veni creator"*, Duruflé; *Carillon de Westminster*, Vierne.

SAMUEL JOHN SWARTZ, University of Redlands, Redlands, CA, February 10: *Chorale II in B Minor*, Franck; *Toccata, Adagio and Fugue*, Bach; *Reflections of Martin Luther King, Jr.*, Sisler; *Variations on "Amazing Grace"*, Utterback; *Antiphon*, Dupré; *Tu es petra*, Mulet.

J. RICHARD SZEREMANY, with Iris Harris, soloist, First Friends Church, Whittier, CA, January 23: *Fantasia in E-flat*, Saint-Saëns; *Noël grand jeu et duo*, Daquin; *Andante cantabile (Symphony IV)*, Widor; *Scherzetto, Clair de lune*, Vierne; *Prelude and Fugue in G Minor*, Dupré; *Mon coeur s'ouvre a ta voix*, Saint-Saëns; *Andantino in D-flat*, Lemare; *In dulci jubilo*, Sowerby; *Sweet Sixteenths*, Albright; *Rhumba*, Elmore; Selections from *Phantom of the Opera*, Lloyd Webber.

STEPHEN THARP, St. Thomas Church, New York, NY, January 10: *Paraphrase-Carillon*, Tournemire; *Suite*, Alain; *Hommage à Igor Stravinsky*, Hakim.

Frank J. Sauter & Sons
4232 West 124th Place • Alsip, Illinois 60658
708/388-3355
Repairing • Contractual Servicing • Rebuilding

Tuning, Repair, Voicing Regulating, Early Pitch and Temperament
Harpichords, Forte pianos Sales, Rentals, Concert & Recording Preparation
Robert H. Turner
Piano/Harpichord Technician
Associate of D. Jacques Way & Marc Duonnel
130 Pembroke Drive Yonkers, NY 10710
Tel (914) 793-1875 FAX (914) 793-0017

PIPE ORGAN BUILDERS - EST. 1877
SCHOENSTEIN
SAN FRANCISCO
3101 20th ST., 94110 • (415) 647-5132

COMPLETE PIPE ORGAN SERVICE
1-708/474-9398
JOHN VROOM Organ Service
18651 Sherman
Lansing, IL 60438

HELLMUTH WOLFF
TRACKER ORGANS
1260 rue Tellier
Laval, Québec H7C 2H2

ROBERT TRIPLETT, Cornell College, Mt. Vernon, IA, March 5: *Praeludium*, S. 552, *Kyrie! Gott Vater in Ewigkeit*, S. 669, *Christe, aller Welt Trost*, S. 670, *Kyrie! Gott heiliger Geist*, S. 671, *Jesus Christus, unser Heiland*, S. 688, *Fuga à 5*, S. 552, Bach; *Suite for Organ*, Duruffé.

JOHN WALKER, Westminster Presbyterian Church, Winnipeg, Manitoba, January 24: *Introduction and Passacaglia in D Minor*, Reger; *Concert Variations on Old Hundred*, Paine; *Moto ostinato*, Eben; *Scherzo (Hymnsonata for Organ)*, Arnatt; *Prelude and Fugue in B Major*, op. 7, no. 1, Dupré; *Choral No. 2 in B Minor*, Franck; *What a friend we have in Jesus*, Bolcom; *Allegretto (Sonata in E-flat)*, Parker; *Impromptu, Carillon de Westminster*, Vierne.

MARIANNE WEBB, Snyder Memorial Baptist Church, Fayetteville, NC, March 14: *Paeun*, Leighton; *Von Gott will ich nicht lassen*, S. 658, *Toccata in C Major*, S. 564, Bach; *Prelude et Fugue*, op. 99, no. 3, Saint-Saëns; *Prelude on "Iam sol recedit igneus"*, Simonds; *Final (Symphonie V)*, Vierne.

ANNE & TODD WILSON, Reorganized Church of Jesus Christ of Latter-Day Saints Auditorium, Independence, MO, March 20: *Variations Symphoniques*, Franck; *The Alexander Variations*, Hampton; *Prelude to Die Meistersinger*, Wagner; *Larghetto (Piano Concerto No. 2 in F Minor)*, Chopin; *Suite from Carmen*, Bizet/James Biery.

RUDOLF ZUIDERVELD, First United Presbyterian Church, Macomb, IL, February 7: *Praeambulum in E Major*, Lübeck; *Ciacona in D Major*, Pachelbel; *Fantasy and Fugue in G Minor*, S. 542, Bach; *A Trumpet Minuet*, Hollins; *Rhosymedre*, Vaughan Williams; *Partita on "How brightly shines the morning star"*, Matter; *Choral No. 1 in E Major*, Franck.

CLASSIFIED ADVERTISING

Classified Advertising Rates will be found below

ALL REPLIES TO BOX NUMBERS that appear without an address should be sent to:
THE DIAPASON
380 Northwest Hwy.
Des Plaines, IL 60016

POSITIONS WANTED

Available: Full time, apprentice, willing to learn all phases of organ work. Have some piano and pipe organ tuning. Willing to relocate within 150 mi. of Poughkeepsie, NY. 914/452-2482.

POSITIONS AVAILABLE

Director, Institute of Sacred Music, Yale University. The Director is tenured and must have training and experience in at least one of the three major areas of Institute involvement: music, worship, and the related arts. Responsibilities: administering budget, leading curricular development, articulating educational vision, strengthening community life, and nurturing the relationship with the Music and Divinity Schools. Appointment begins 1 July 1994. Send letter of application, curriculum vitae, and three references to: Ann Ameling, Associate Provost, Institute of Sacred Music, 409 Prospect St., New Haven, CT 06511 by 31 July 1993. Yale University is an equal opportunity/affirmative action employer.

POSITIONS AVAILABLE

Organist, Glenview Community Church (UCC). Position available September 1. Two Sunday services, one choir rehearsal, additional special services and rehearsals. Salary negotiable based on education and experience. Possible handbell involvement, 3-manual Moller organ 1957. Contact: Organist Search Committee, Glenview Community Church, 1000 Elm St., Glenview, IL 60025.

Church organist. Call for details. 708/299-5561. First Congregational Church UCC, Des Plaines, IL. Northwest Chicago suburb.

MISCELLANEOUS

BRUSTWERK HEADPHONES. Attention organists: Save your hearing before it's too late! This exclusive new product protects your ears against the onslaught of even the nastiest Brustwerk divisions! **BRUSTWERK HEADPHONES** (or "Brusties") will stand up against VII-X rank Scharffs and Zimbels, even the dreaded Terzzimbell! With these comfortable, long-lasting BRUSTIES, you can play for hours with little or no damage to your hearing, even when the Brustwerk is "in your face." Developed in consultation with a leading airline's ground crew, BRUSTIES are sturdy and can filter out up to 200 decibels (the level of your average Brustwerk mixture), and come in designer liturgical colors. Exclusive offer for Diapason readers only! Order today! BOX "BRUSTIE", c/o THE DIAPASON.

MISCELLANEOUS WANTED

8' Haskell basses; 16' Haskell strings; low end 16' Vox; small-scale, light-winded Trompette. 615/383-0417.

Richard Peel wants used D.E. Wicks chests, parts, pipes; 16' Reed, Bombarde, Tibias, Flutes, Diap. 16'-2', String Chorus, solo reeds, pipe facade. From So. California only. Star Rt. 1, Box 697, Banning, CA 92220.

Wanted: to contact person at the Moller auction who may have purchased old pipes in trays marked R-105 or 11855. REPLY TO BOX JL-1, THE DIAPASON.

PUBLICATIONS/ RECORDINGS

The Organ Literature Foundation, world's largest supplier of organ books and recordings, offers Catalogue "AA" listing 742 books, 3154 classical organ LPs, Cassettes and CDs, etc. Send \$2 or 5 international reply coupons. The Organ Literature Foundation, 45 Norfolk Rd., Braintree, MA 02184-5918. 617/848-1388.

A complete listing of all available back-numbers of THE DIAPASON is now available. Many from the 1930s on, and some older issues may also be obtained for your personal or library collection. Send SASE to: The Organ Historical Society, Box 26811, Richmond, VA 23261.

The Organ Historical Society is offering a 32-page catalog of publications, recordings, and other items, many of which are produced by the OHS. The catalog also includes many hard-to-find popular recordings and books from other sources. Send 45¢ stamp to: OHS, Box 26811, Richmond, VA 23261.

Member APOBA (317) 637-5222
Goulding & Wood, Inc.
823 Massachusetts Ave. Indianapolis, IN 46204

A. David Moore, Inc.
TRACKER ORGAN DESIGNERS & BUILDERS
HC 69 Box 6, North Pomfret, Vermont 05053
802/457-3914

BERGHAUS ORGAN CO. INC.
708-544-4052 Fax 708-544-4058
537 South 25th Avenue • Bellwood, Illinois 60104

ORGANS BY
Gabriel Kney
137 FALCON STREET.
LONDON, ONTARIO, CANADA.
N5W 4Z3 (519) 451-3210

J.F. NORDLIE COMPANY
PIPE ORGAN BUILDERS
504 South Charlotte Avenue
Sioux Falls, South Dakota 57103-2612
1-800-456-0834

TAYLOR & BOODY ORGAN BUILDERS
George K. Taylor John H. Boody
Route 1, Box 58 B, Staunton, Virginia 24401
Telephone: (703) 886-3583

Bunn • Minnick Company
Excellence in Pipe Organ Building and Service
875 Michigan Avenue
Columbus, Ohio 43215
(614) 299-7934

LEVSEN ORGAN COMPANY
P.O. BOX 542, BUFFALO, IOWA 52728 (800) 397-1242

ROSALLES ORGAN BUILDERS INC.
249 EAST FIFTH STREET • LOS ANGELES, CALIFORNIA 90012
(213) 262-9153

Robert M. Turner Organbuilder
15732 Tolley Street, #39
Hacienda Heights, CA 91745 (818) 814-1700

CLASSIFIED ADVERTISING RATES

Regular classified advertising is single paragraph "want ad" style. First line only of each ad in bold face type.

Display classified advertisements are set entirely in bold face type with the addition of a ruled box (border) surrounding the advertisement.

Regular Classified, per word	\$.50
Regular Classified minimum	8.00
Display Classified, per word	.75
Display Classified minimum	25.00

Additional to above charges:
Box Service (mail forwarding) 7.00

NOTE: Orders for classified advertising must be accompanied by payment in full for the month(s) specified. Orders will be accepted for one, two, three, four, five, or six months in advance.

Non-subscribers wanting single copies of the issue in which their advertisement appears should include \$2.00 per issue desired with their payment.

The Diapason reserves the right to designate appropriate classification to advertisements, and to reject the insertion of advertising deemed inappropriate to this magazine.

THE DIAPASON • 380 NORTHWEST HIGHWAY • DES PLAINES, IL 60016

insert the advertisement shown below or enclosed in the Classified Advertising section of THE DIAPASON for the following issue(s):

Category _____ Regular Boldface

Ad Copy _____

PAYMENT MUST ACCOMPANY ORDER

Name _____ Phone _____
Address _____ Total Enclosed _____
City/State _____ Zip _____ Date Sent _____

CLASSIFIED ADVERTISING

Classified Advertising Rates will be found on page 21

PUBLICATIONS/ RECORDINGS

Historic Organs of San Francisco features 20 historic pipe organs in the San Francisco Bay area recorded in June, 1988 during the Organ Historical Society's National Convention, available as a two-cassette or two-compact disc set more than two hours long. Both formats include a 28-page booklet with histories and stoplists of the organs heard. Twenty organists perform 31 works by 30 composers. Order cassettes or CDs from the OHS Catalog, Box 26811, Richmond, VA 23261 at \$22.95 plus \$1.50 shipping and handling.

HARPSICORDS

Neupert harpsichords, clavichords, fortepianos new and used. Wally Pollee, 1955 W. John Beers Rd., Stevensville, MI 49127.

PIPE ORGANS FOR SALE

Kilgen; 2 manuals, 7 1/2 ranks, 17 stops; detached console; pipes excellent condition. 719/545-0769 after 3 pm Mountain Standard Time.

Hinners tracker, 1M/6R, divided keyboard, restored and playing in our shop. Very affordable price. Julian Bulley Pipe Organs, 1376 Harvard Blvd., Dayton, OH 45406. 513/276-2481.

3/38 Casavant (1922) rebuilt by Wicks 1935; Casavant pipework, direct electric chests, handsome tiered drawknob console, echo division. Very good condition. Must sell. \$28,000. 313/994-5144.

Replies to Box Numbers should be sent to The Diapason, 380 Northwest Hwy., Des Plaines, IL 60016

PIPE ORGANS FOR SALE

Two-manual 1958 Moller, 12 straight stops, some octave unification. All electric tilting tablet console. Presently in storage. Excellent condition throughout. Available as is, or can be rebuilt with minor tonal changes. Sacrifice. Quality Organ Service, Inc., 2231 Melholland Rd., Lawrence, KS 66047, 913/749-5423.

Exquisite 8-rank tracker built by Van Daalen (1980). Two manuals plus coupler manual. Beautiful cabinet. Well-built, excellent condition. \$50,000. 507/246-5195.

2M Estey; needs pipes, mechanics in excel- lent condition and recently re-leathered. Sell organ or its parts. 714/497-8583.

Moller Artiste organs: 1953 3R rolloff con- sole, \$14,000; 1961 4R, \$18,000. Holtkamp self-contained 5R practice, \$22,000. Rivé, Inc., 811 Focis St., Metairie, LA 70005.

3M Moller; drawknob console, chimes, com- pletely re-leathered, well maintained, and in excellent condition in all departments. New reeds, mixtures, and other flue ranks. Can be played up until June 1, 1993. Contact: 714/497-8583.

1884 Hilborne Roosevelt tracker organ 2M, 21R, 17 stops. Rebuilt and enlarged with Pedal reed. Carved walnut case. Approx. 16' wide x 9' deep x 14' tall. Owner must sell immediately. Asking \$65,000 OBO. Patrick J. Murphy & Associates, Old Reading Pike, Suite 1D, Stowe, PA 19464. 215/970-9817. Serious inquiries only.

THEATRE ORGANS FOR SALE

Theatre Organ, 2-manual and pedal console, walnut bench, 49-note Deagan harp, celeste, 6 ranks; blower. Please make offer. Call: 216/428-7397 in evenings or weekends.

THEATRE ORGANS FOR SALE

Allen theater organ, 61/61/32 AGO, ADC-5300 DK, D-1605, \$7,000. Send SASE for photo and voicing. Stratemeier, 1705 Weatherstone Dr., Blue Springs, MO 64015. 816/229-6316.

Gottfried 2M, 12 rank unit organ with Theater console, French Trumpet, Clarinet, Vox Humana, and Deagan Harp. R. Wagner, 242 Old Mill Rd., Erie, PA 16505-1029. Tel 814/833-5924.

2-manual, 7-rank Wuriltzer? Milwaukee thea- ter organ, 1941 Roesler-Hunholz church installation (complete or parts) plus 1920's Austin pipes. Salem Lutheran Church, 2822 6th Street N, Wausau, WI 54401. 715/845-2822.

REED ORGANS

Address Change: Phoenix Reed Organ Res-urrection; New Address: HCR 33, Box 28, Townshend, VT 05353. 802/365-7011. 2-MP reed organs, with or without pipetop; replacement reeds; parts, restorations.

ELECTRONIC ORGANS WANTED

Hammond B-3/C-3 organs wanted! Cash paid. Nationwide pickup, sold worldwide. Help us save the B-3's! Leslies needed. Keyboard Exchange International, 8651 Portside Ct., Orlando, FL 32817. 407/677-7001; fax 407/671-2272. Please send photos.

ELECTRONIC ORGANS FOR SALE

Rodgers Model 220 Cambridge; 2-manual AGO drawknob console; 2 M13-100 speaker cabinet; 1 Leslie ML-200 cabinet. Mint condition. Asking \$8,250. Call Bill: 714/738-1569 home, 714/529-0821 work.

ELECTRONIC ORGANS FOR SALE

2-manual Baldwin church organ. Being re- placed with pipe organ. Terry Williams, FBC Madison, NC. 919/548-6112.

Must sell Baldwin organ model 645. Walnut finish, 3 manual & pedal. External amplifier plus 3 speaker cabinets. Bought new 1985 for home use. Rarely used. Best offer over \$15,000. Write (REPLY BOX JN-1, THE DIAPASON) or call daytime 312/372-5123.

1992 Hammond 825 digital AGO spec. organ. Digitally sampled; pipe voices, drawbars, chimes & piano. Digital reverb, sequencer, pistons & animation; 2 manual, 32 pedal. \$5,000 delivery included. Other 32-pedal consoles available from \$1,000. Doug Jackson Electronics. 414/642-9732.

Allen, Rodgers, Baldwin organs! Used and reconditioned two and three-manual instruments. Bought/sold. Ideal for home or church. Great bargains on handyman specials! Inventory list and brochure available. Save big bucks! Worldwide and nationwide delivery. Keyboard Exchange International, 8651 Portside Ct., Orlando, FL 32817. 407/671-0730; fax 407/671-2272.

MISCELLANEOUS FOR SALE

16' Principal, 10' scale, mitered; 3-manual 1947 Austin console, 4-stop Reuter chest, Swells, SLIC motors, tracker pipes. 816/279-4700 or 816/446-2082.

1840 Hook & Hastings 8' Open Wood Cello; fair condition, incomplete. \$250.00. Call Jim after 5:00 pm. 717/738-0464.

Fifty dual magnetic stop assemblies with reed contacts; stop tabs included; A-1 condition. \$10.00 each OBO. P. Deltman, Box 1152, Kalaheo, HI 96741.



ORGAN SUPPLY INDUSTRIES

A vital part of American Organ Building, providing quality pipe organ supplies.
P.O. Box 8325 • Erie, PA 16505 • 814-835-2244



SEBASTIAN MATT. GLUCK ORGELBAU
PIPE ORGAN CONSERVATORS, ARCHITECTS, AND BUILDERS
175 FIFTH AVENUE
SUITE 2198
NEW YORK, NEW YORK 10010
TELEPHONE (212) 924-4184



Reuter
Preferred Pipe Organs
P.O. Box 486 Lawrence, KS 66044
(913) 843-2622

BELLS

CHIME SYSTEMS • CARILLONS • ELECTRIFICATION
TOLL FREE 1-800-544-8820
vanBergen Bellfoundries, Inc.

Traditional Quality Craftsmanship
Electro-Pneumatic Actions • New Organs
Tracker Restorations • Electrical Renovations

P.O. Box 24 • Davidson, NC 28036
1-800-446-2647
Fax 704-892-4266

Benjamin K. Williams
Owner



Knowlton Organ Co.
Member:
American Institute of Organbuilders

**For Sale
This Space
Write for
Advertising Rates**

STEINER-RECK

Incorporated
ORGANBUILDERS

415 East Woodbine Street
Louisville, KY 40208
(502) 634-3636

VISSER-ROWLAND

713/688-7346
2033 JOHANNA B
HOUSTON 77055

Member
International Society of Organbuilders
Associated Pipe Organ Builders of
America



ANDOVER

Modern Mechanical Action
New Organs • Restorations • Rebuilding
P.O. Box 36, Methuen, Massachusetts 01844
Telephone (508) 586-9600

Quality Parts and Service
Since 1966

SEND 35 SO TODAY FOR OUR
85 PAGE CATALOG

**ARNDT ORGAN
SUPPLY COMPANY**
1018 LORENZ DRIVE P.O. BOX 129
ANKENY IOWA 50021
PHONE (515) 984 1274

Telephone: (705) 435-9367



PAUL F. MARTIN
Tracker Organs

R.R. #1, Mansfield, Ontario, Canada L0N 1M0

FOR SALE

This space, as low as \$30 per issue on a 12-insertion contract. Want more details? Rate card sent on request.

THE DIAPASON
380 Northwest Highway
Des Plaines, IL 60016

Pipe Organ Sales and Service, Inc.
P O Box 838 • Lithonia Ga 30058 • 404 482-4845
Serving Pipe Organs of All Types in the Southeast

Consulting Rebuilding
Additions Annual Maintenance
Repairs Contracts
New Organs

Prestant Pipe Organs, Inc.

P.O. Box 5099 San Antonio, Texas 78201
(512) 782-5724
(512) 494-1540



Redman Organ Co.
816 E. VICKERY BLVD.
FORT WORTH, TX 76104
(817) 332-2953

MEMBER INTERNATIONAL SOCIETY OF
ORGANBUILDERS ASSOCIATED PIPE
ORGAN BUILDERS OF AMERICA

ORGAN BUILDING/RESTORATION

T. R. RENCH & CO.

RACINE, WIS. 53403

1405 SIXTEENTH ST. • 414/633-9566

Known for Quality

Manufacturer of Organparts:
OTTO HEUSS KG
POBox 1162 6302 LICH W. Germany



HEUSS

ORGELTEILE

CLASSIFIED ADVERTISING

Classified Advertising Rates
will be found on page 21

MISCELLANEOUS FOR SALE

New items: Laukhuff Harmitron SX-401 tuner and temp probe \$1,800; OSI pipe racking jig \$170; Laukhuff tongue shear \$280; Organ Cadd \$500; Lucas sound level meter \$600; 50 amp Astron power supply \$180; 35 amp Astron \$120; Forstner bit set \$250; Peterson 320 tuner \$200. 219/432-3794.

3-manual Moller console with Ivory keys. For specifications contact St. John's Episcopal Church, 101 South Prospect St., Hagerstown, MD 21740, or call 301/733-2560.

Selection of used pipes, chests, blowers for sale. SASE. A&J Reed & Pipe Organ Service, 36 Carter St., Newburgh, NY 12550. 914/561-1480.

19 ranks of pipes with chests, etc. from 2-manual organ. Austin console. Hugh Donnell, Day 501/727-5476. Night 501/727-5470. Morrilton, AR.

3-manual drawknob console, matching re-lays, 5, 6, 7 Rk. DE chests, Spencer blowers, 16" Principal 9" sc. 3 1/2" WP, 8" French Horn Gottfried 10" WP, 16" Quintadena, 4" Spitz Flute, more. SASE for list. R.J. Brunner & Co., Box 46, Silver Spring, PA 17575. 717/285-3545.

4-manual Moller console; Ivory keyboards in excellent condition, recently rebuilt for temporary use on large organ. 152 new Harris drawknob motors, includes new set of blank stop jamba for up to 240 knobs; 26 tilting tablets. \$25,000; internal coupler and combination can be supplied at additional cost. The Bishop Organ Company, 88 Foundry Street, Wakefield, MA 01880-3204. 617/245-3228.

Four-rank Wicks organ No. 36170. \$4,500. Estey two-manual reed organ No. 440122, \$1,800. Hammond C/3 \$3,500. P.O. Box 1104, Scott, LA 70583. 318/232-4347.

Austin 3M console, 1925; 30 stops, 25 couplers, 6-stop echo, 11 generals. Refinished. \$2,500/offer. 206/462-8207.

MISCELLANEOUS FOR SALE

35-rank Aeolian-Skinner vintage pipework and chests, many reeds. New Reiser D.E. magnets, 1 1/2" pallets, K-A relays and switches. Call Carlo. 718/829-4418; 607/652-8033.

Used Reuter organ parts, SASE. Beeston Pipe Organ Service, 2606 47th St., Des Moines, IA 50310. 515/277-7383.

Facade: approx. 30' (long) x 20' (high) x 4' (deep). Semi-circle, tower on either end. Approx. 50 pipes in facade. 714/497-8583.

Korg MT1200 Tuner. \$275 (list \$360). Hears A0-C8. Plays C2-B5. Shows pitch, note, octave. Can program calibration, temperament. Korg AT12 Tuner. \$155 (list \$225). Song of the Sea, 47 West St., Bar Harbor, ME 04609. 207/288-5653. Brochures.

Used pipes and organ equipment, SASE. Lee Organs, Box 2061, Knoxville, TN 37901.

EP chest clearance. Pitman, unit and offset chests by Organ Supply, Schantz, Reuter and Moller. Various ages and conditions. Some with Mixture stops, some with built-in relays, some with frames. Also, shades and reservoirs. SASE to Randall Dyer & Assoc., Box 489, Jefferson City, TN 37760.

SERVICES/ SUPPLIES

"The Pneumatic Works" Specializing in all types of releathering. Write: 76 Ed Clark Rd., Colrain, MA 01340, or phone 413/624-3249.

3 & 5 HP blowers, static pressure 5" to 15". New from White Blower Mfg. Co. All American made, 2 year guarantee, quiet operation, under-sells all other sources. For catalog and more information call 1-800/433-4614. 2540 Webster Rd., Lansing, MI 48917.

SERVICES/ SUPPLIES

MIDI COMPATIBLE MODULAR CONTROL SYSTEM for pipe & electronic organs using +10V to +17V keying, stop & magnet voltage. This modular system has been designed for small to medium size instruments. Each module uses just three types of circuit boards; Input, Processor & Output. They can be arranged to become one or any combination of the following systems: 1) Organ Keyboard to sound module interface. 2) Record-Playback using a MIDI Sequencer. 3) Complete organ relay for up to three manuals/pedal and 256 stop keys. 4) Eight memory level capture type combination action with five programmable crescendo levels. Features are low cost, ease of adding additional capability & simplicity of wiring. All interconnections are by ribbon cable with plug-in junction strips and MIDI connectors. Phone or write Devtronix Organs, Inc., 1823 Avondale Ave., Sacramento, CA 95825. 916/971-9074; fax 916/971-9075.

Call or write for quote. Custom solid-state switching and coupling system. NO plug-ins, NO chips, and NO assembly required. Fast turnaround. Simply connect your chest and keyboard cables to our terminal board. NE Organ Systems, 441 Main St., Biddeford, ME 04005. 1-800/370-7473.

Releathering. Burness Associates can provide all your releathering in our modern well-equipped shop. We specialize in Skinner, Casavant, and Moller pouch boards and actions. We can also provide services on the actions of other manufacturers. Burness Associates, P.O. Box 564, Montgomeryville, PA 18936. 215/368-1121.

REEDS—Prompt repair of damaged pipes. Careful cleaning and renovation of old stops at wind pressures up to 12". New resonators for "half-length" stops to improve tone and tuning. Voicing done in our shop or on site. Packing materials supplied for safe transport. Herbert L. Huestis and Associates, #101, 1482 Gulf Rd., Point Roberts, WA 98201. Phone 604/946-3952; FAX 604/946-5739; CompuServe # 70771,1047. Inquiries invited for consultation on special problems or projects.

SERVICES/ SUPPLIES

Austin actions recovered. Over 20 years experience. Units thoroughly tested and fully guaranteed. Manual motor \$32.40 t.o.b. Technical assistance available. Foley-Baker, Inc., 1212 Boston Trnkp., Bolton, CT 06043. 1-800/621-2624.

Solid State relay for pipes. Save 50% by assembling these simple printed circuit modules to make any relay configuration required. Highest quality components supplied. Write for information: Devtronix Organs, Inc., 1823 Avondale Ave., Sacramento, CA 95825.

Combination Action, capture type. Least expensive and most reliable system available. Modular form lets you buy only what is required. Compatible with any relay. Not a kit. Write for information: Devtronix Organs, Inc., 1823 Avondale Ave., Sacramento, CA 95825.

Low note pedal generator for pipes. Will supply all 32 notes at pitches and voices required. Single tuning adjustment. Power amplifiers and speakers to match the installation. Compare our low price to others. Write for information: Devtronix Organs, Inc., 1823 Avondale Ave., Sacramento, CA 95825.

Classified Ads must be prepaid, and may be ordered for 1, 2, 3, 4, 5, or 6 months.

ALL REPLIES TO BOX NUMBERS that appear without an address should be sent to:
THE DIAPASON
380 Northwest Hwy.
Des Plaines, IL 60016

Harris Precision Products

Builders of high quality
Pipe Organ Components

7047 S. Comstock Avenue, Whittier, California 90602 U.S.A. • (213) 693-3442

David C. Harris, Member: International Society of Organ Builders, American Institute of Organ Builders, Associated Pipe Organ Builders of America

REPAIRING TUNING ADDITIONS

R. W. KURTZ ORGAN CO.

CONSULTANT SPECIALISTS ON PIPE ORGAN REBUILDING
P. O. Box 32, Woodstown, N. J. 08098 • 609 / 769-2883



W. Zimmer & Sons, Inc.

pipe organ builders

Telephone (704) 588-1706
Mailing Address: P. O. Box 520
Pineville, N. C. 28134



Artisan Builders

806 NP Ave.
Fargo, N. Dak. 58102
(701) 293-8964
Wood Organ Pipes

(212) 757-3503

Christopher A. Balled

PIPE ORGAN BUILDER

NEW INSTRUMENTS
TUNING/MAINTENANCE
REBUILDS 205 WEST 54TH STREET
TONAL WORK NEW YORK, NY 10019

JULIAN E. BULLEY

New Organs — Rebuilding
Service
SINCE 1906

1376 Harvard Blvd.—Dayton, Ohio 45406
513-276-2481

DURST PIPE ORGAN & SUPPLY COMPANY

817 Old Boones Creek Road
Jonesborough, TN 37659
(615) 753-4521

William R. Durst

Reservoirs Chests Termoloss
Swell Engines Swell Fronts
Quality from the Past Competitive for the Future



Greenwood Organ Co.

"Three Generations at Organ Building"

CHARLOTTE, NORTH CAROLINA 28218

P.O. Box 18254 704/334-3819

GUZOWSKI & STEPPE

ORGANBUILDERS INC

NEW INSTRUMENTS
REBUILDS - ADDITIONS
TUNING & SERVICE

4717 NORTHEAST 12TH AVENUE
FT LAUDERDALE, FL 33334
(305) 491-6852

Klug & Schumacher, Inc.

PIPE ORGANS

Tuning, Repairs, Rebuilds
Additions, Relocations
1708 Atlanta Ct

Lakeland, Florida 33803
Phone (813) 687-9425

Lewis & Hitchcock, Inc.

Pipe Organ Builders Since 1915

8466-A Tyco Road

Vienna, VA 22182

1-800/952-PIPE

CHARLES W. McMANIS

Voicer & Tonal Finisher

20 Cowles Road

Woodbury, CT 06798



AUSTIN ORGANS, INC.

FLORIDA/GEORGIA REPRESENTATIVES

P.O. Box 2562
HUGH M. PIERCE PALM BEACH, FLORIDA 33480
THOMAS R. THOMAS (407) 833-2087



PROSCIA ORGANS

MICHAEL PROSCIA ORGANBUILDER, Inc.
BOX 547 • BOWDOON, GEORGIA 30108 • (404) 258-3388



Tel. 03404-13827

Your personal wishes
are in good hands

Jacques Stinkens 3701 VE ZEIST
Organ pipe makers B.V. Holland

THE DIAPASON

380 E. Northwest Highway • DesPlaines, IL 60016-2282

NEW SUBSCRIBER
 RENEWAL
ENCLOSED IS

\$36.00—3 years
 \$27.00—2 years
 \$18.00—1 year

Foreign subscriptions:

\$60.00—3 years
 \$43.00—2 years
 \$28.00—1 year

Please allow four weeks for delivery of first issue on
new subscriptions

Karen McFarlane Artists

12429 Cedar Road, Suite 5
Cleveland, Ohio 44106
(216) 721-9095/9096
(216) 721-9098 (FAX)



William Albright



Guy Bovet +



Stephen Cleobury* +



David Craighead



Michael Farris



Gerre Hancock*



Judith Hancock



Martin
Haselbock +



David Higgs



Clyde Holloway



Peter Hurford +



Marilyn Keiser



Susan Landale +



Olivier Latry



Joan Lippincott



Thomas Murray



Peter Planyavsky +



Simon Preston*



George Ritchie



Daniel Roth +



Larry Smith



Donald Sutherland



Frederick Swann



Ladd Thomas



Thomas Trotter +



John Weaver



Gillian Weir +



Todd Wilson



Christopher Young

Choral Conductors*
George Guest
David Hill
Martin Neary

+ = available 1993-94